

FLEX™ MONITOR SERIES

INSTRUCTION FOR INSTALLATION, OPERATION, AND MAINTENANCE

⚠ DANGER

Understand manual before use. Operation of this device without understanding the manual and receiving proper training is a misuse of this equipment. Obtain safety information at tft.com/serial-number.

This equipment is intended for use by trained and qualified emergency services personnel for firefighting. All personnel using this equipment shall have completed a course of education approved by the Authority Having Jurisdiction (AHJ).

This instruction manual is intended to familiarize firefighters and maintenance personnel with the operation, servicing, and safety procedures associated with this product. This manual should be kept available to all operating and maintenance personnel.

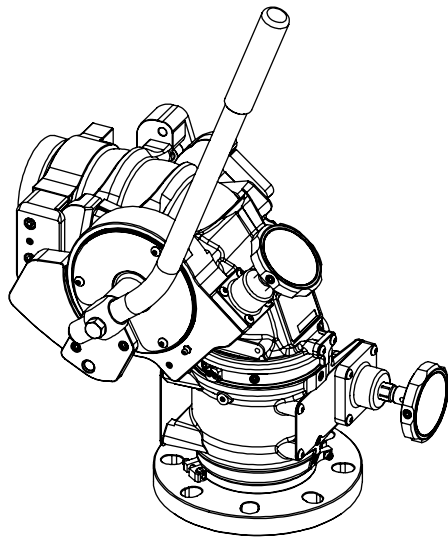

**FLEX
WITH TILLER**

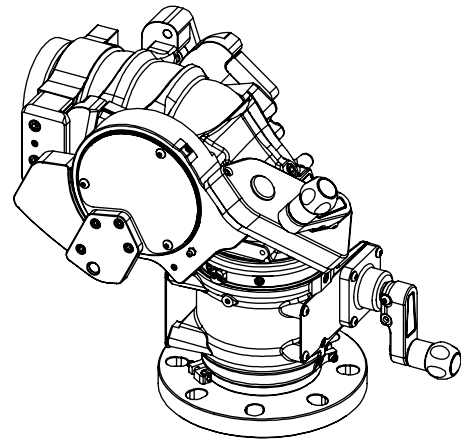

**FLEX
WITH CRANK**

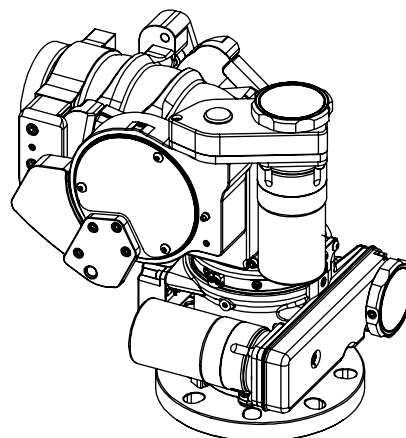

FLEX RC

(see [section 3.2](#)) for Flow/Pressure Operations Envelope

DANGER

PERSONAL RESPONSIBILITY CODE

The member companies of FEMSA that provide emergency response equipment and services want responders to know and understand the following:

1. Firefighting and Emergency Response are inherently dangerous activities requiring proper training in their hazards and the use of extreme caution at all times.
2. **IT IS YOUR RESPONSIBILITY** to read and understand any user's instructions, including purpose and limitations, provided with any piece of equipment you may be called on to use.
3. **IT IS YOUR RESPONSIBILITY** to know that you have been properly trained in Firefighting and/or Emergency Response and in the use, precautions, and care of any equipment you may be called upon to use.
4. **IT IS YOUR RESPONSIBILITY** to be in proper physical condition and to maintain the personal skill level required to operate any equipment you may be called upon to use.
5. **IT IS YOUR RESPONSIBILITY** to know that your equipment is in operable condition and has been maintained in accordance with the manufacturer's instructions.
6. Failure to follow these guidelines may result in death, burns or other severe injury.

Fire and Emergency Manufacturers and Service Association, Inc.
PO Box 147, Lynnfield, MA 01940 - www.FEMSA.org

© 2020 FEMSA. All Rights Reserved.



TABLE OF CONTENTS

- 1.0 MEANING OF SAFETY SIGNAL WORDS
- 2.0 SAFETY
- 3.0 GENERAL INFORMATION
 - 3.1 MECHANICAL SPECIFICATIONS
 - 3.2 OPERATING ENVELOPE
 - 3.3 USE WITH SALT WATER
 - 3.4 VARIOUS MODELS AND TERMS
 - 3.5 INLETS AND OUTLETS
 - 3.5.1 OUTLET ADAPTER
 - 3.6 OVERALL DIMENSIONS
- 4.0 INSTALLATION
 - 4.1 ELECTRICAL INSTALLATION
 - 4.2 STRUCTURAL REQUIREMENTS
 - 4.3 TWO-PIECE ROTATIONAL LOCK INSTALLATION
 - 4.4 CABLE ROUTING FOR EXTEND-A-GUN
 - 4.5 FLEX INSTALLATION ON VUM
 - 4.6 HORIZONTAL ROTATION TRAVEL STOPS
 - 4.7 INSTALLING THE HORIZONTAL TRAVEL STOPS
 - 4.8 ELEVATION TRAVEL STOPS
 - 4.9 NOZZLE INSTALLATION
 - 4.10 PRESSURE GAUGE PORT
 - 4.11 TILLER HANDLE INSTALLATION
 - 4.12 DRAINING RESIDUAL WATER
- 5.0 OPERATING INSTRUCTIONS
 - 5.1 HANDWHEEL HORIZONTAL ROTATIONAL CONTROL
 - 5.2 HANDWHEEL ELEVATION CONTROL
 - 5.3 TILLER BAR CONTROL
 - 5.4 RECOMMENDED PARK POSITION
 - 5.5 OVERRIDE KNOBS
- 6.0 FLOW CHARACTERISTICS
 - 6.1 YST-4NN STACKED TIPS FLOW AND REACH
 - 6.2 MST-4NJ STACKED TIPS FLOW AND REACH
 - 6.3 EFFECTS OF ELEVATION AND WIND ON STREAM REACH
 - 6.4 AUTOMATIC MASTERSTREAM NOZZLES
 - 6.5 FRICTION LOSS
 - 6.6 STREAM STRAIGHTENERS
 - 6.6.1 STREAM STRAIGHTENERS WITH STACKED TIPS
 - 6.6.2 STREAM STRAIGHTENERS WITH FOG NOZZLES
- 7.0 WARRANTY
- 8.0 MAINTENANCE
 - 8.1 SERVICE TESTING
 - 8.2 LUBRICATION
 - 8.3 TROUBLESHOOTING
 - 8.4 REPAIR
- 9.0 EXPLODED VIEWS AND PARTS LISTS
- 10.0 OPERATION AND INSPECTION CHECKLIST

1.0 MEANING OF SAFETY SIGNAL WORDS

A safety related message is identified by a safety alert symbol and a signal word to indicate the level of risk involved with a particular hazard. Per ANSI Z535.6, the definitions of the four signal words are as follows:



DANGER indicates a hazardous situation which, if not avoided, will result in death or serious injury.



WARNING indicates a hazardous situation which, if not avoided, could result in death or serious injury.



CAUTION indicates a potentially hazardous situation which, if not avoided, could result in minor or moderate injury.



NOTICE is used to address practices not related to physical injury.

2.0 SAFETY



An inadequate supply of pressure and/or flow will cause an ineffective stream and can result in injury or death. Choose operating conditions to deliver adequate fire suppression. See flow graphs.



Injury or damage can occur from an inadequately supported monitor. The mounting must be capable of supporting the nozzle reaction force which can be as high as 1500 lbs.



The stream exiting a nozzle is very powerful and capable of causing injury and property damage. Make sure the nozzle is securely attached and pointing in a safe direction before water is turned on. Do not direct water stream to cause injury or damage to persons or property.



Equipment may be damaged if frozen while containing significant amounts of water. Such damage may be difficult to detect visually. Subsequent pressurization can lead to injury or death. Any time the equipment is subject to possible damage due to freezing, it must be tested and approved for use by qualified personnel before being considered safe for use.



On many vehicle installations, the monitor is the highest point on the apparatus. Damage or injury could occur if there is not sufficient clearance to safely pass under doors or overhead obstructions. Always check stowed position of the monitor before moving.



The electric drives are current limited but may still produce enough force to cause injury. To avoid injury from moving equipment:

- Be aware that equipment may be remotely operated
- Keep hands and fingers away from pinch points
- Never operate the manual override while electric controls are in operation

3.0 GENERAL INFORMATION

FLEX is a mounted master stream monitor/ water cannon with flow ranges from 1250 GPM (4750 LPM) to 2000 GPM (7600 LPM).

The unique design minimizes curves in the waterway, lowering friction loss, resulting in a higher-quality, further reaching water stream. Paired with the FLEX Ops app, the monitor is customizable and simple to install and program.

3.1 MECHANICAL SPECIFICATIONS

	MANUAL		ELECTRIC	
	US	METRIC	US	METRIC
Weight*	33 to 39 lbs	15 to 18 kg	42 to 47 lbs	19 to 21 kg
Minimum Flow Area (4" Inlet x 3.5" Outlet)	9.6 in ²	61.9 cm ²	9.6 in ²	61.9 cm ²
Minimum Flow Area (3" Inlet x 2.5" Outlet)	4.9 in ²	31.6 cm ²	4.9 in ²	31.6 cm ²
Maximum Operating Pressure	200 psi	14 bar	200 psi	14 bar
Nominal Operating Voltage	n/a	n/a	12 or 24 VDC (auto sense)	
Maximum Voltage	n/a	n/a	32 VDC	
Operating Temperature Range of Fluid	33°F to 120°F / 1°C to 50°C			
Storage Temperature Range	-40 to 150°F / -40 to 65°C			
Maximum Torque (Elevation)	n/a		80 ft-lbs	110 N·m
Maximum Torque (Horizontal)			60 ft-lbs	80 N·m
Speed (Elevation)	n/a		6 deg/sec	
Speed (Horizontal)			12 deg/sec	
Speed at Maximum Load (Elevation)	n/a		5 deg/sec	
Speed at Maximum Load (Horizontal)			10 deg/sec	
Materials	ANSI A356.0-T6 Aluminum, Stainless, Nylon			

* Weight varies by model, see website listing for specific model weight.

Table 3.1

3.2 OPERATING ENVELOPE



Damage or injury could result from operating the monitor beyond the safe operating envelope. Do not operate the monitor outside the envelope in the following graph(s).

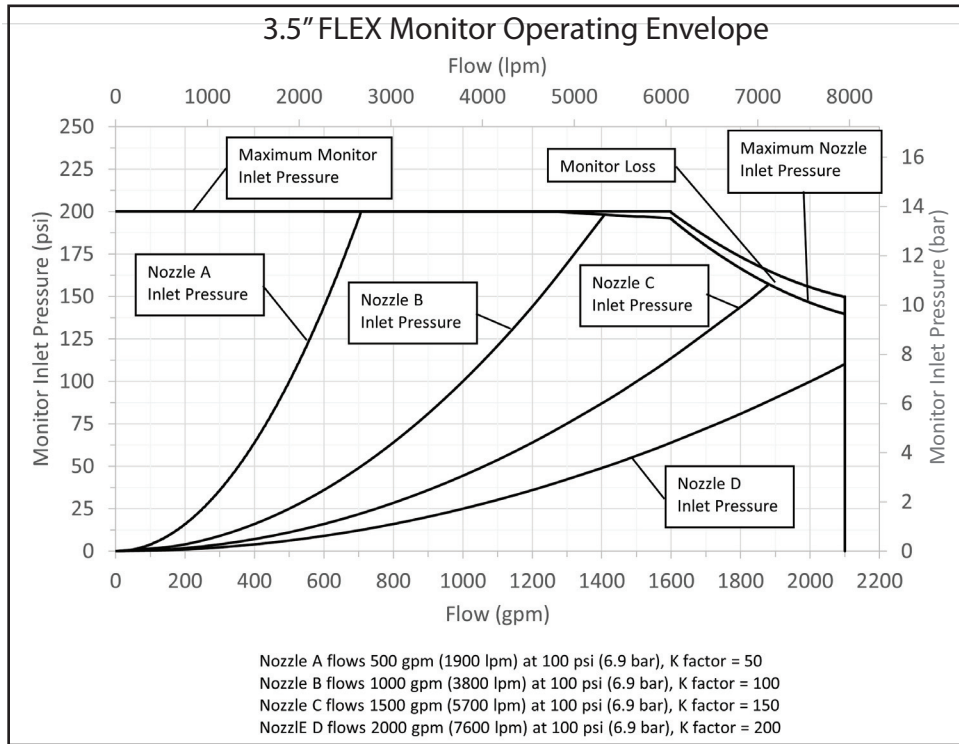

Figure 3.2A

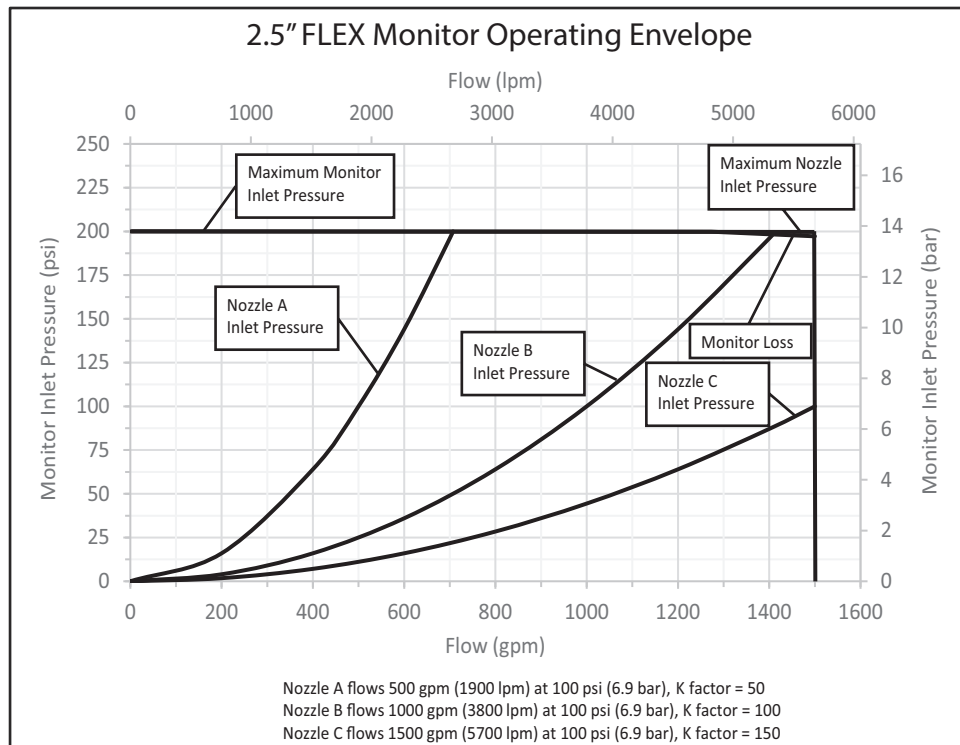

Figure 3.2B

3.3 USE WITH SALT WATER

Use with salt water is permissible provided the equipment is thoroughly cleaned with fresh water after each use. The service life of the equipment may be shortened due to the effects of corrosion, and is not covered under warranty.

3.4 VARIOUS MODELS AND TERMS

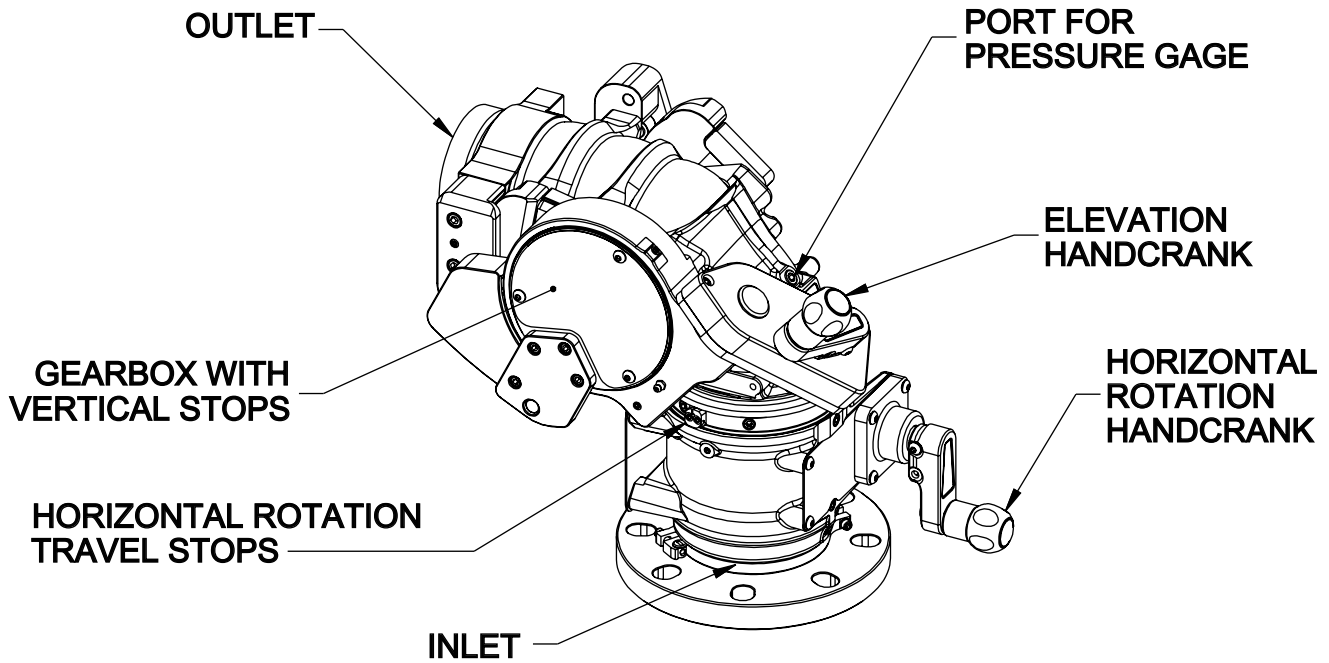

Figure 3.4A
Manual Model with Crank

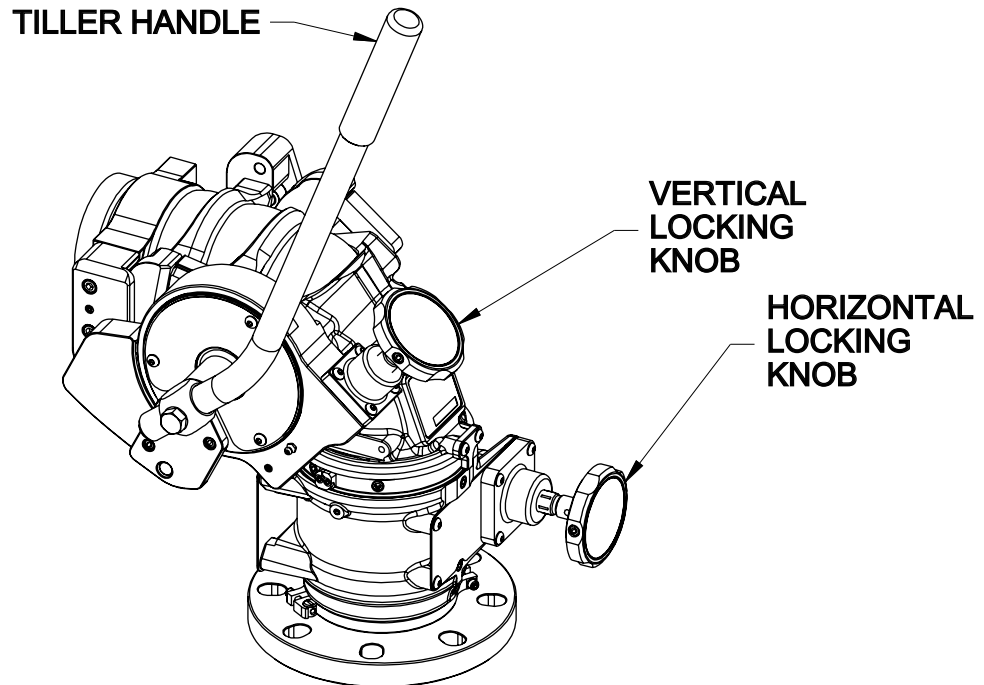

Figure 3.4B
Manual Model with Tiller

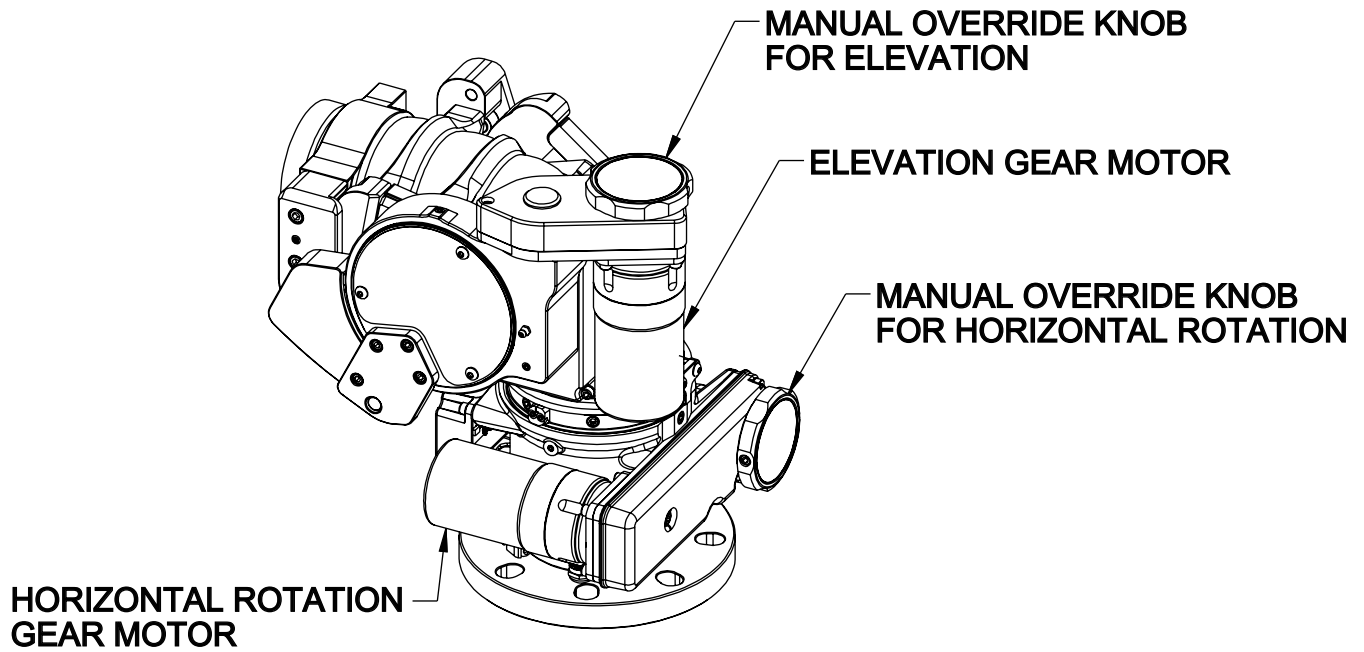

Figure 3.4C
RC Model

3.5 INLETS AND OUTLETS

There is a wide variety of inlet and outlet options for the FLEX monitor. The overall height and weight of the monitor may differ slightly based on the inlet and outlet configuration. See finished good drawing on the website listing for specific model dimensions.

3.5.1 OUTLET ADAPTER

FLEX monitors with 2.5" threaded outlets may easily be converted to 3.5"NH threads by tightening four screws surrounding the outlet, then unscrewing the 2.5" threaded outlet and O-ring using a strap wrench.

3.6 OVERALL DIMENSIONS

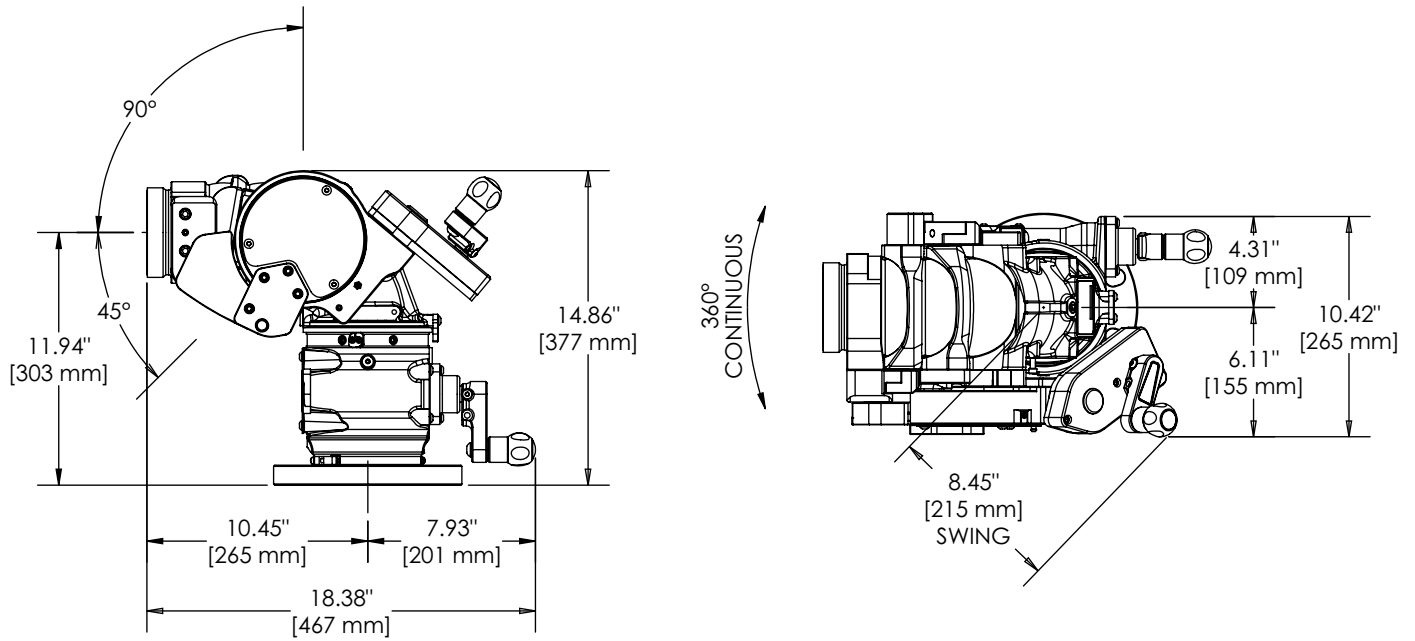

Figure 3.6A
Manual Model with Crank
(Shown with 4" ANSI 150 inlet, see finished good drawing on the website for specific model dimensions)

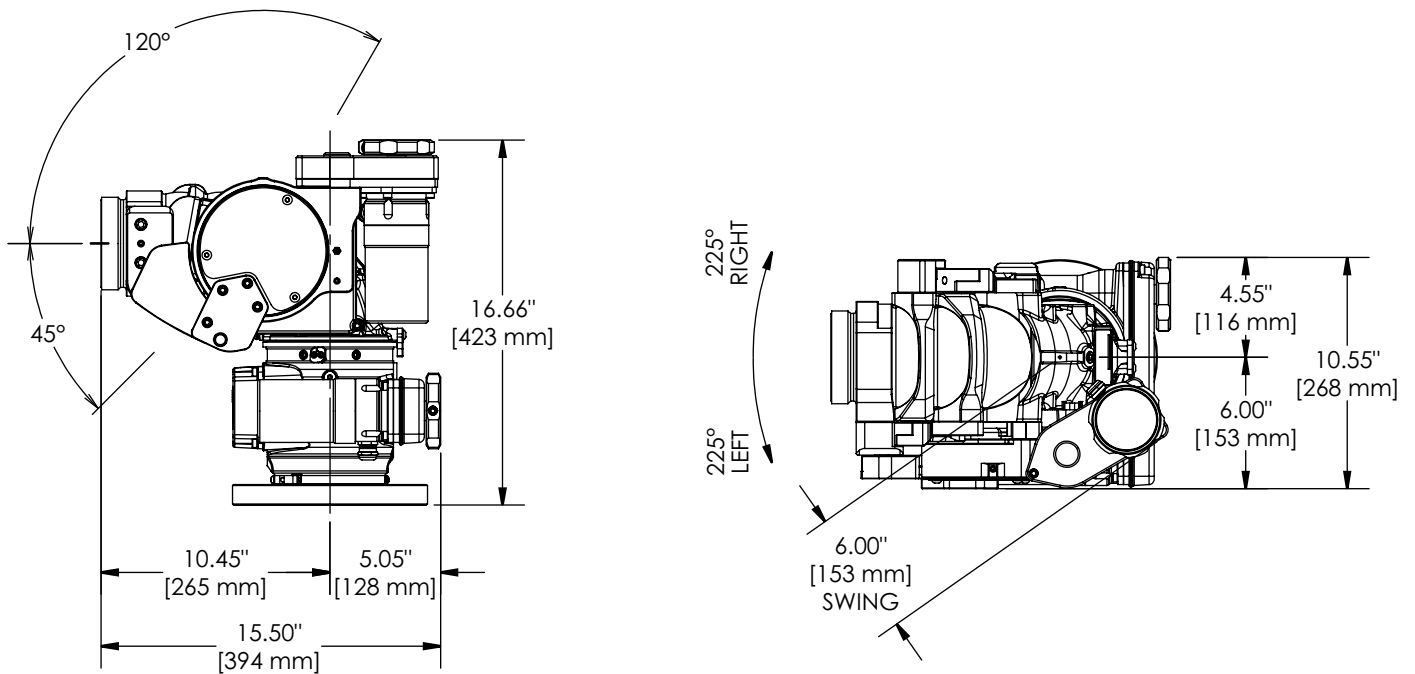

Figure 3.6B
RC Model
(Shown with 4" ANSI 150 inlet, see finished good drawing on the website for specific model dimensions)

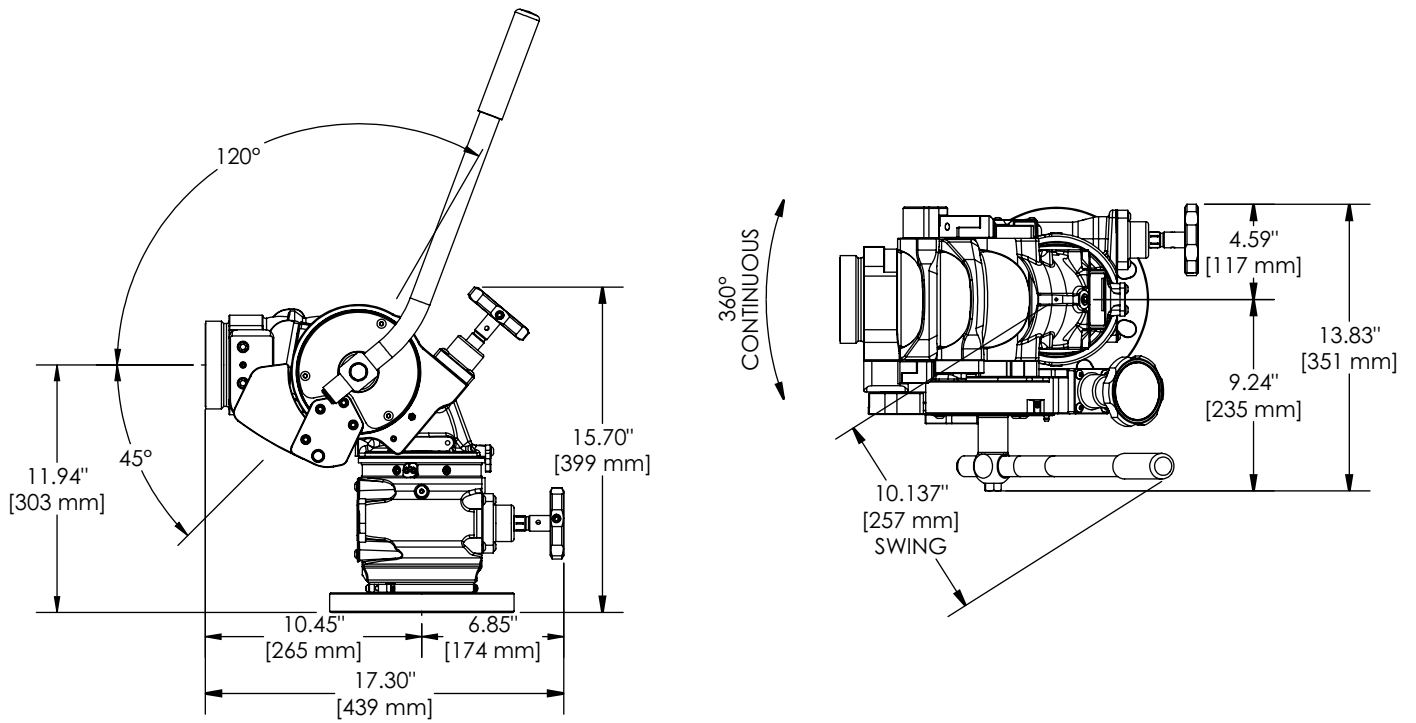

Figure 3.6C
 Manual Model with Tiller
 (Shown with 4" ANSI 150 inlet, see finished good drawing on the website for specific model dimensions)

4.0 INSTALLATION

4.1 ELECTRICAL INSTALLATION

See Remote Control (RC) Monitor Electrical Controls Supplemental Instructions LIY-550.

4.2 STRUCTURAL REQUIREMENTS



Reaction forces generated by master stream flows are capable of causing injury and property damage if not properly supported. Monitors should be securely installed by qualified individuals.

- Mounting objects must be capable of withstanding maximum nozzle reaction force.
- The monitor must be securely mounted to rigid support members.
- Do not use flanges or pipe made from plastic for monitor mounting.
- Torque all fasteners to specified values.

The structure that the monitor is mounted to must withstand the internal pressure of the monitor as well as shear and bending forces due to nozzle reaction. Nozzle reaction can be as high as 1500 lbs (700 kg)(2000 gpm at 200 psi).

For flanged connections, the use of flat flanges without raised faces is recommended. Use a ring gasket as defined in ASME 16.21 or ISO 7483. Tighten flange bolts in an alternating sequence as shown below. Tighten sequentially each bolt or stud three times to 30%, then 60%, and finally 100% of the specified torque. Tighten to a total of 76-80 ft-lb (100-110 N·m).

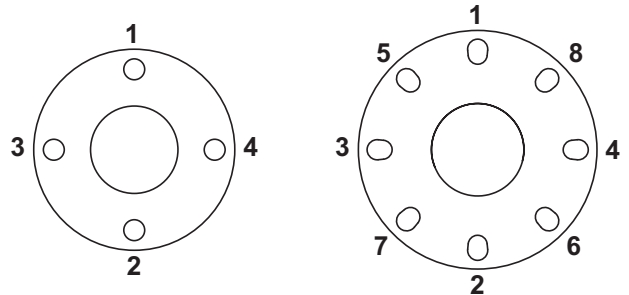

Tighten Sequentially Each Bolt Three Times to a Total of 76-80 ft-lb (100-110 N·m)

FLANGE TYPE	OPTION #	OUTSIDE DIAMETER		THICKNESS		BOLT HOLE CIRCLE		# OF BOLTS	SIZE OF BOLTS	
		in	mm	in	mm	in	mm		in	mm
3" ANSI 125/150-DN80 PN20	1	7.5	190	0.75	20	6.0	152.5	4	5/8	16
4" ANSI 150-DN100 PN20	2	9.0	230	0.94	23	7.5	190	8	5/8	16
6" ANSI 150 Flange	3	10.9	277	1.0	25.4	9.5	241.3	8	5/8	16
DN80, PN16 Flange	4	7.9	200	0.87	22	6.3	160	8	5/8	16
DN100, PN16 Flange	5	8.7	220	0.87	22	7.1	180	8	5/8	16

Table 4.2

4.3 TWO-PIECE ROTATIONAL LOCK INSTALLATION

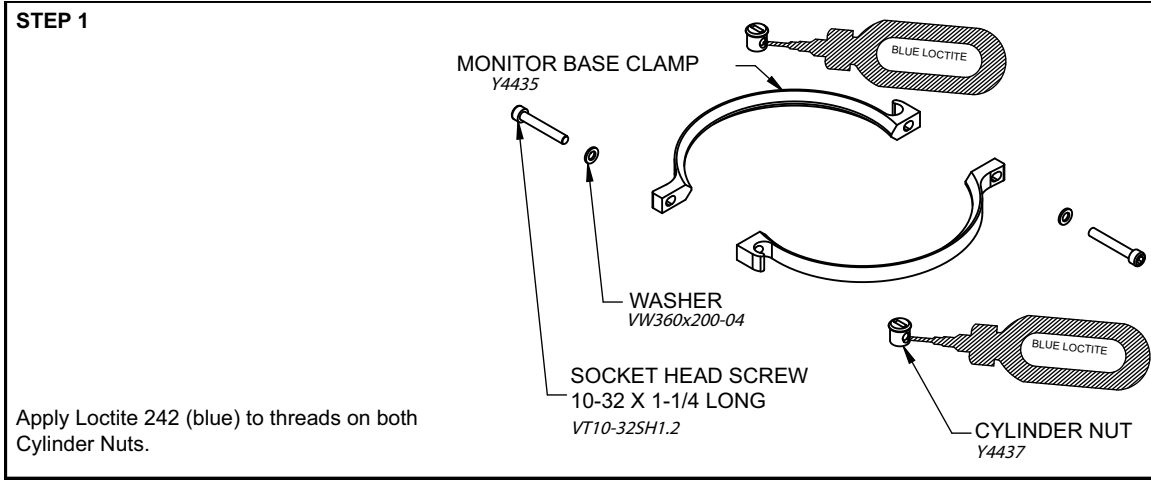

Figure 4.3A

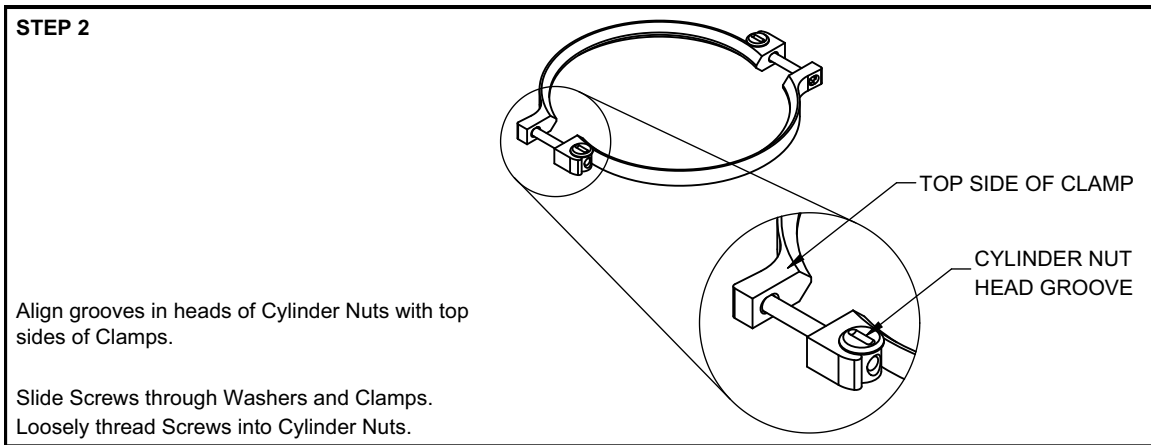
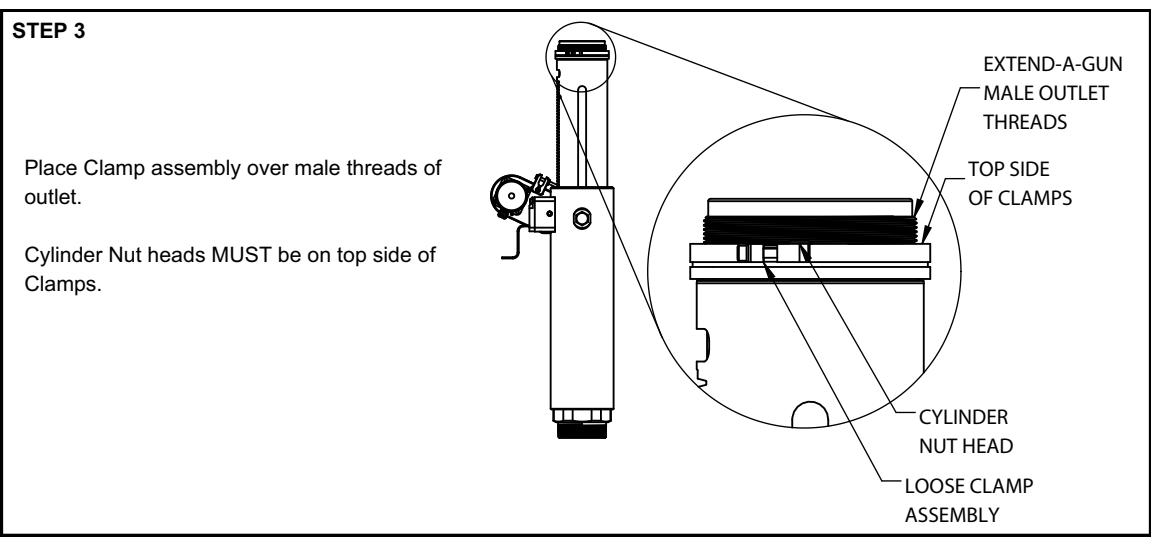

Figure 4.3B



STEP 4

Screw monitor onto Extend-A-Gun until monitor base bottoms out against Extend-A-Gun outlet.

Threaded joint seals with an O-ring and will leak if monitor base bottoms out on Clamp assembly instead of Extend-A-Gun outlet.

Do not use pipe dope or Loctite on threads. Use of thread locking compounds is unnecessary and will make removal difficult.

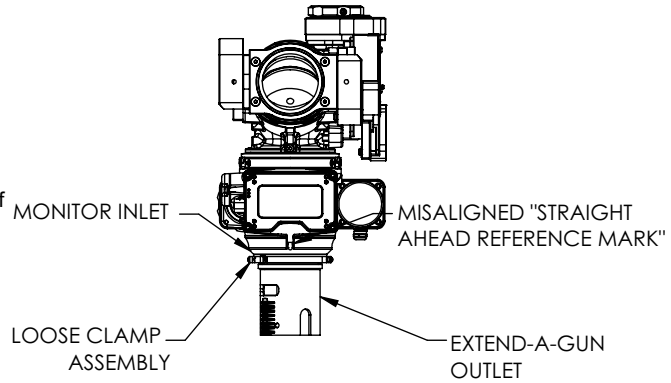

Figure 4.3C

STEP 5

Unscrew monitor base from Extend-A-Gun outlet until "Straight Ahead Reference Mark" is facing desired direction. *

Monitor may be unscrewed up to one full rotation from bottomed-out condition. Monitor will leak if unthreaded more than one rotation (360°) from bottomed-out condition.

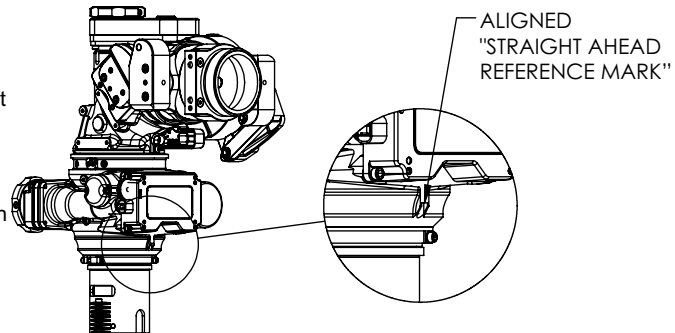

Figure 4.3D

STEP 6

Rotate clamps to desired position and tighten Screws until finger tight. Maintain equal spacing between Clamp ends.

Tighten Screws one additional turn using a 5/32" (4mm) hex wrench. Alternate Screws each half-turn.

To avoid damage to the monitor, ensure Clamps do not interfere with RC monitor Power/Com cable and that Screws are not overtightened.

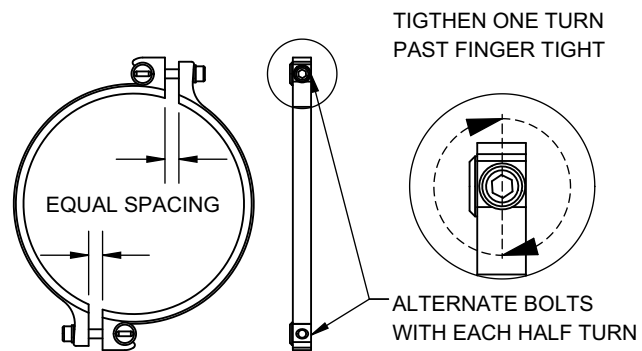

Figure 4.3E

4.4 CABLE ROUTING FOR EXTEND-A-GUN

When using a FLEX monitor on an Extend-A-GUN RC, route the cable as shown in the image below. Use the wire clamp provided on the Extend-A-Gun RC to secure the wire to the Extend-A-Gun gearbox.

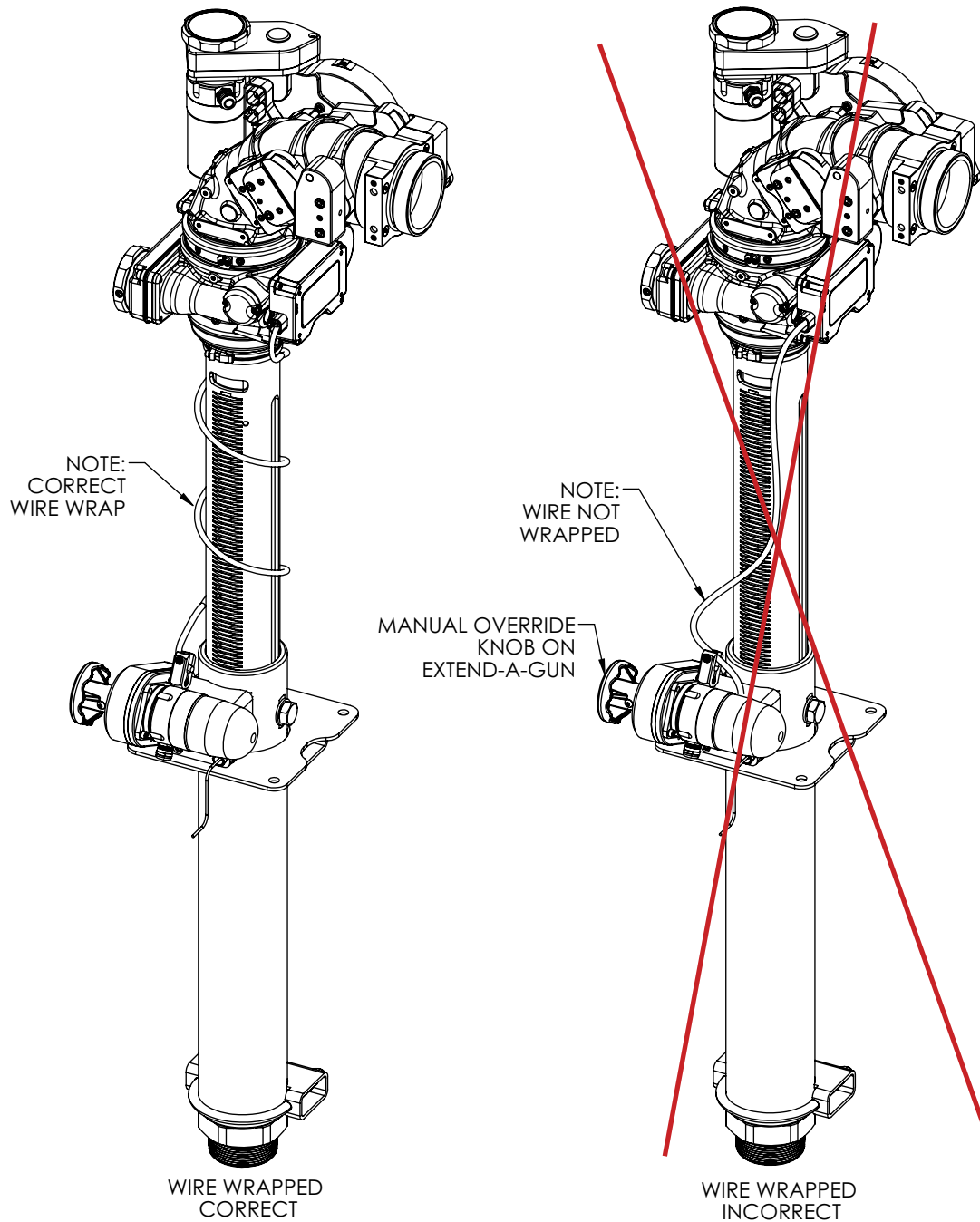

Figure 4.4
Extend-A-Gun Cable Routing

The Extend-A-Gun manual override knob may be mounted in any of four possible orientations (90 degrees apart) relative to the Straight Ahead Reference Mark on the monitor.

4.5 FLEX INSTALLATION ON VUM

Due to the many possible VUM configurations, when installing FLEX on a VUM, select VUM model configurations may have interference with a FLEX monitor. In these cases, it is recommend to use the extension piece provided with FLEX Code-RPF Inlet Models. This extension will raise the height of the monitor by 1.5".

4.6 HORIZONTAL ROTATION TRAVEL STOPS

The range of horizontal rotation travel for the manual FLEX monitor is continuous 360 degrees. The motorized version is limited to 450 degrees total horizontal rotation travel, or 225 degrees from either side of a straight ahead position. Horizontal rotation travel stops may be installed at any position on the monitor to limit travel. Note that left and right are relative to the "Straight Ahead Reference Mark" and refer to the nozzle's discharge direction as seen from an operator's position behind the nozzle.

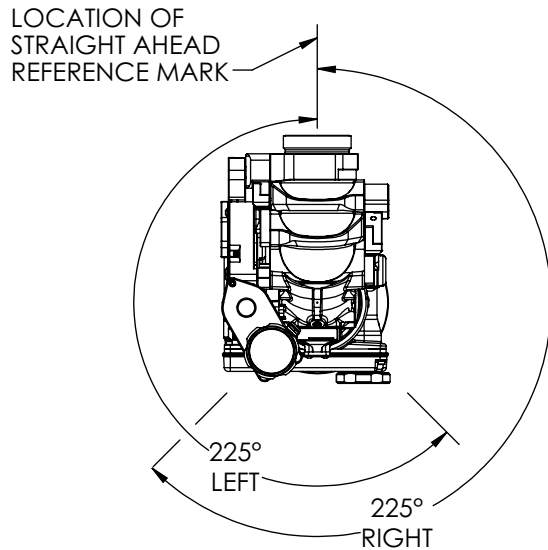

RC MODELS WITH NO TRAVEL STOPS INSTALLED HAVE A HORIZONTAL ROTATIONAL TRAVEL LIMIT OF 225° LEFT AND RIGHT OF THE STRAIGHT AHEAD REFERENCE MARK

MANUAL MODELS WITH NO TRAVEL STOPS INSTALLED HAVE A CONTINUOUS 360° HORIZONTAL ROTATIONAL TRAVEL

Figure 4.6A

Horizontal Rotation Travel Limits for RC Models

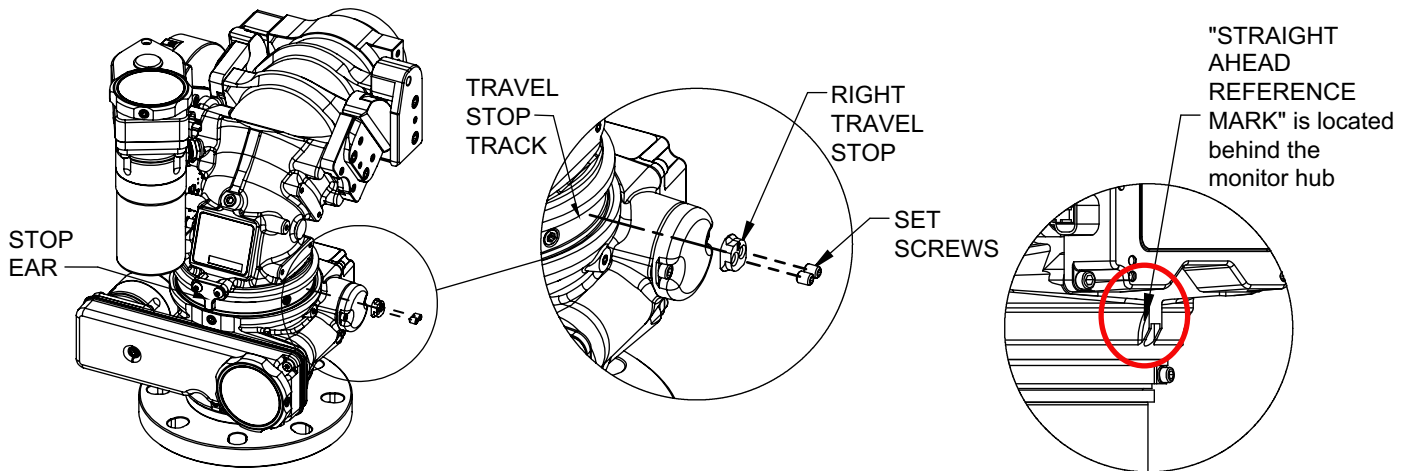

Figure 4.6B

Horizontal Rotation Travel Stops

4.7 INSTALLING THE HORIZONTAL TRAVEL STOPS

To install the Horizontal Travel Stops:

1. Align the monitor discharge with the Straight Ahead Reference Mark.
2. When facing the back of the monitor, the travel stop marked "L" must be installed on the left-hand side, and the travel stop marked "R" must be installed on the right-hand side.
3. Hold the travel stop with the letter (L or R) facing up, rotate the travel stop 90° and insert into the coupling track.
4. Rotate back to the original position with the letter facing up.
5. Move the monitor to the desired end of travel and slide the travel stop against the stop ear on the monitor. To aid setting the travel stops at left/right angles of exactly 45, 90 or 135°, the stop positions can be set by aligning the "L" or "R" marking with one of the shallow notches located just above the travel stop track.
6. Apply Loctite® 242 (blue) to the screw threads and tighten set screws to lock the travel stop position.
7. Repeat for the other side.

4.8 ELEVATION TRAVEL STOPS

The range of elevation travel for the FLEX Monitor is 30 degrees past vertical to 45 degrees below horizontal. The elevation range may be limited by installing the supplied stop bolts at the locations as shown. The figures include installation notes.

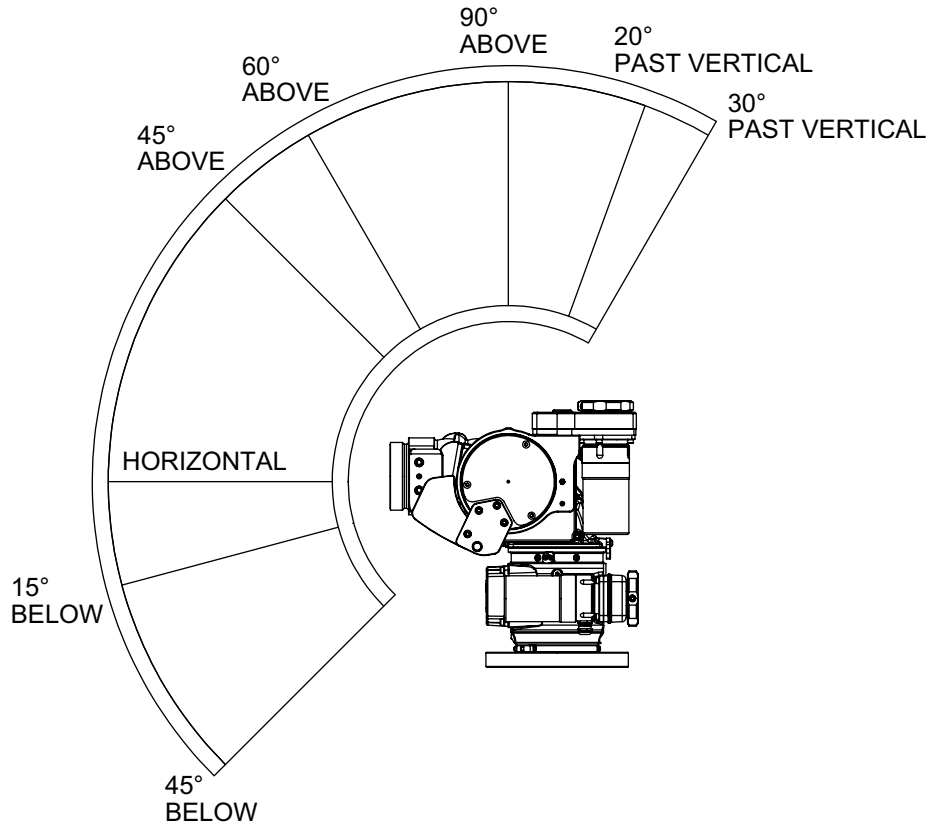

Figure 4.8A
Elevation Travel Limits

Stop Bolt Installation Instructions:

1. Remove 3 button head screws.
2. Remove cover plate.
3. Remove set screws.
4. Apply Loctite 242 (blue) to the stop bolts. Install stop bolts to obtain desired travel limits. Elevation travel with no stop bolts is 30 degrees past vertical and 45 degrees below horizontal.
4. Install Cover plate.
5. Apply Loctite 242 (blue) to the button head screw threads and tighten screws to secure cover plate.

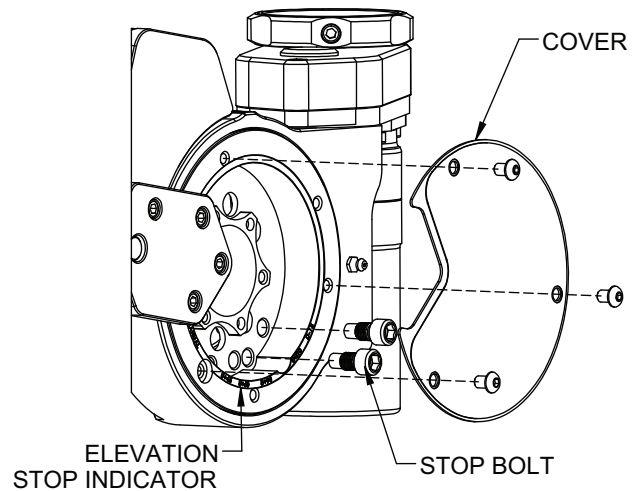

Figure 4.8B
Elevation Travel Stop Locations

4.9 NOZZLE INSTALLATION

The nozzle is simply screwed onto the monitor's exit threads. If the nozzle is installed on a FLEX RC (with electric motors) assure that the nozzle's actuator does not make contact with the horizontal drive chain and motor housings when the monitor is in its lowest elevation position.

CAUTION

Mismatched or damaged waterway connections may cause equipment to leak or uncouple under pressure. Failure could result in injury. Equipment must be mated to matched connections.

CAUTION

Dissimilar metals coupled together can cause galvanic corrosion that can result in the inability to uncouple the connection, or complete loss of engagement over time. Failure could cause injury. Per NFPA 1962, if dissimilar metals are left coupled together, an anti-corrosive lubricant should be applied to the connection and the coupling should be disconnected and inspected at least quarterly.

4.10 PRESSURE GAUGE PORT

There is a 1/4" NPT female threaded hole on the back of the monitor. The hole is plugged from the factory. If a pressure gauge is desired, unscrew the plug and install the gage using pipe sealant. Make sure the gauge does not interfere with operation.

4.11 TILLER HANDLE INSTALLATION

For tiller models, the handle is shipped loose from the monitor and must be installed to complete the installation process. When installing the tiller handle ([see Figure 5.3](#)), be sure to coat the threads of the mounting screw with the Loctite supplied in the hardware packet.

4.12 DRAINING RESIDUAL WATER

There is no drain on the FLEX monitor itself. A drain valve should be installed on the piping to which the monitor is attached.

WARNING

Monitors, valves, and piping may be damaged if frozen while containing sufficient amounts of water. Such damage may be difficult to detect visually and can lead to possible damage, injury, or death. Equipment that may be exposed to freezing conditions must be drained immediately following use to prevent damage.

CAUTION

Structural damage from corrosion can result from failure to drain appliance between uses. Damage from corrosion can cause injury due to equipment failure. Always drain appliance between uses.

5.0 OPERATING INSTRUCTIONS

See Remote Control (RC) Monitor Electrical Controls Supplemental Instructions LIY-550 for operation of the FLEX RC Monitors.

5.1 HANDWHEEL HORIZONTAL ROTATIONAL CONTROL

A handwheel controls the monitor's horizontal rotation direction. Counterclockwise rotation of the handwheel moves the nozzle to the left and clockwise rotation to the right. Approximately 14 turns of the handwheel will give a 90 degree change in horizontal rotation direction.

5.2 HANDWHEEL ELEVATION CONTROL

A handwheel controls the monitor's elevation direction. Clockwise rotation of the handwheel lowers the elevation and counterclockwise raises it. About 60 turns of the handwheel will give the complete 165 degree elevation travel range of the monitor.

5.3 TILLER BAR CONTROL

On the Tiller Bar model, the horizontal and vertical rotation is changed by pushing or pulling horizontally on the Tiller Handle. Twisting the Rotation Locking Knob clockwise will increase the drag on the lower swivel joint to "lock" the monitor in a particular direction.

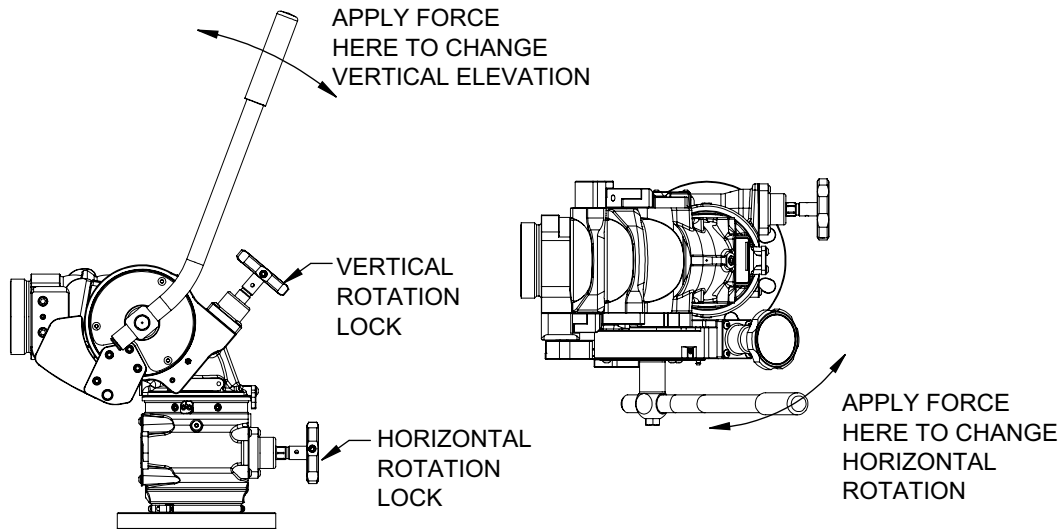

Figure 5.3

WARNING

Debris in the nozzle may cause off center nozzle reaction. Injury or damage from spinning or sudden movement of the monitor could occur. To reduce the risk of an out of control monitor:

- Always check for waterway obstructions before flowing water
- Always keep the rotation lock tight when not rotating the monitor
- Always keep one hand on the tiller handle when loosening the rotation lock
- When 360° rotation is not needed, install horizontal rotation stop bolts to limit monitor travel

5.4 RECOMMENDED PARK POSITION

For truck mounted applications, it is recommended that the monitor be parked in a position such that the monitor's nozzle rests against a bracket or support surface. If a support surface is not available, run the elevation against one of the travel stops to take some of the backlash out of the gear drive. This will minimize bouncing of the nozzle when the apparatus is traveling. Always be sure the monitor is properly parked before moving the truck and know the overall height to avoid damage from overhead obstructions such as doors or bridges. See LIY-550 for information on programming PARK position.

5.5 OVERRIDE KNOBS

In the event of electrical system failure on the monitor or fire truck, the FLEX RC may be manually operated with factory supplied override knobs. To make the FLEX RC more compact, the manual override knobs may be removed. Removing the override knobs exposes a hex so an 11/16" wrench or socket may be used for manual override.

6.0 FLOW CHARACTERISTICS

6.1 YST-4NN STACKED TIPS FLOW AND REACH

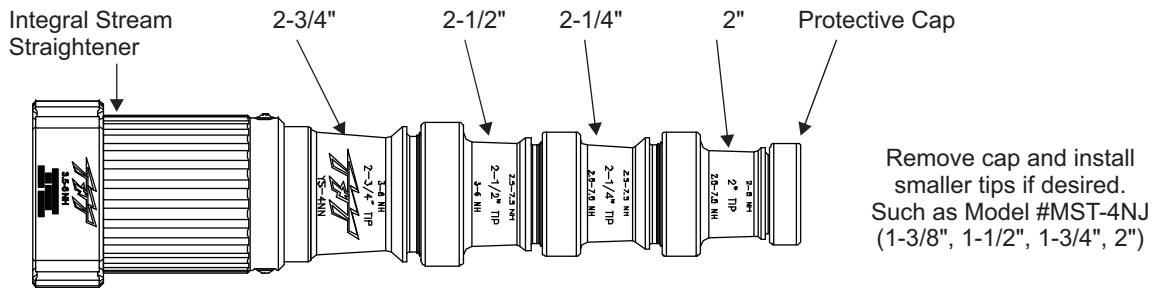

Figure 6.1A

Stacked Tip Model YST-4NN

NOZZLE DIAMETER	NOZZLE INLET PRESSURE							
	50 PSI		60 PSI		80 PSI		100 PSI	
	FLOW (GPM)	REACTION (LBS)	FLOW (GPM)	REACTION (LBS)	FLOW (GPM)	REACTION (LBS)	FLOW (GPM)	REACTION (LBS)
2.00"	840	310	920	380	1060	500	1190	630
2.25"	1080	400	1170	480	1350	640	1500	790
2.50"	1310	490	1440	590	1660	785	1860	980
2.75"	1590	590	1740	710	2010	950	---	---

NOZZLE DIAMETER	NOZZLE INLET PRESSURE							
	3.5 BAR		4.1 BAR		5.5 BAR		7 BAR	
	FLOW (L/min)	REACTION (KG)	FLOW (L/min)	REACTION (KG)	FLOW (L/min)	REACTION (KG)	FLOW (L/min)	REACTION (KG)
50 mm	3180	140	3480	170	4010	230	4500	290
57 mm	4010	180	4430	220	5110	290	5680	360
64 mm	4960	220	5450	270	4680	360	7040	450
70 mm	6020	270	6590	320	7610	430	---	---
---	FLOW EXCEEDS RATING OF FLEX MONITOR							

Table 6.1

YST-4NN Flow and Reaction Force

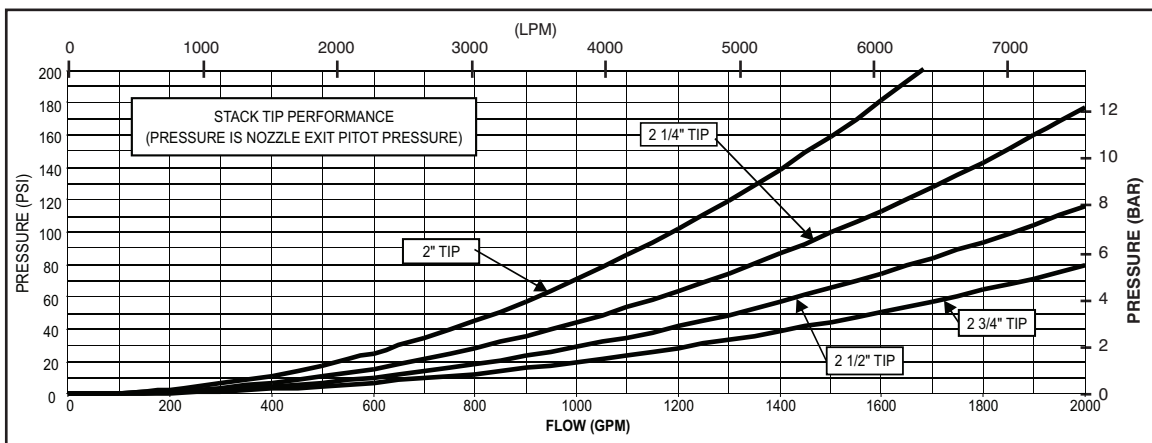

Figure 6.1B

YST-4NN Flow Graph

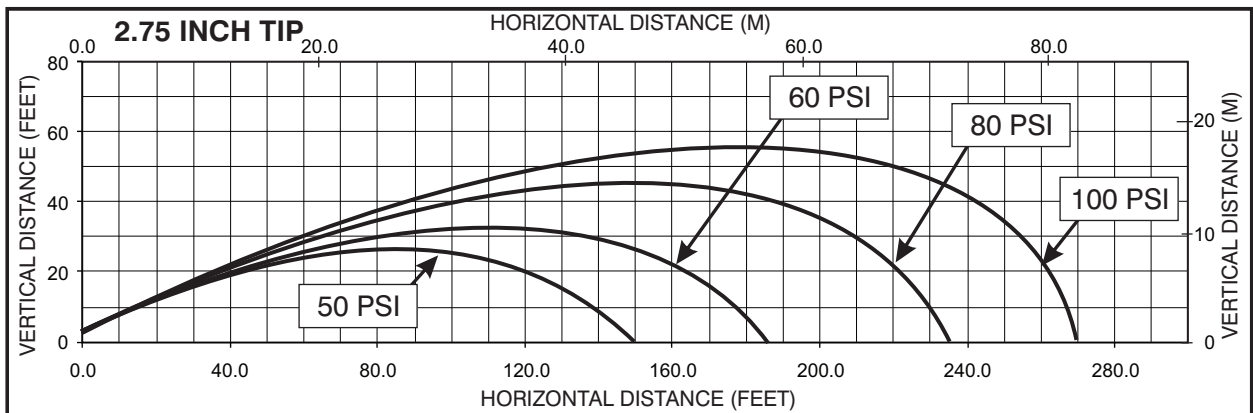
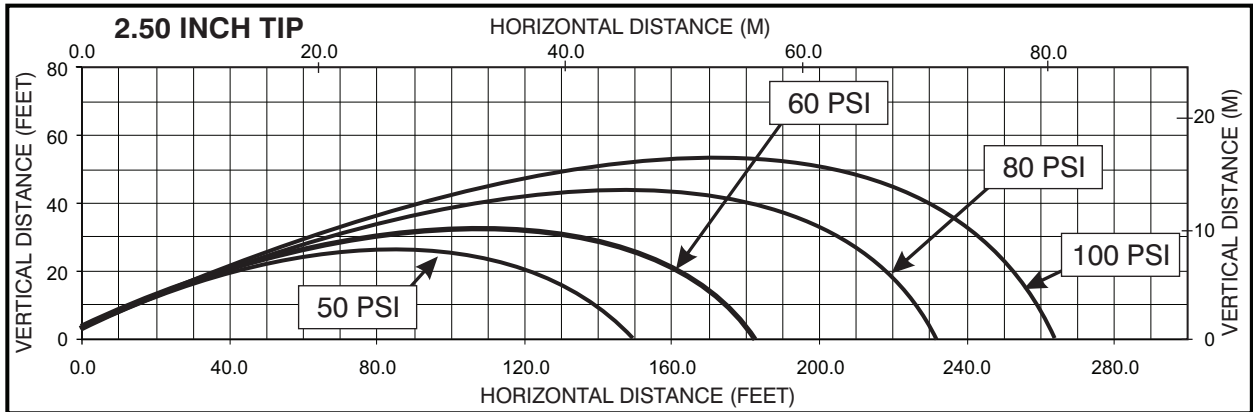
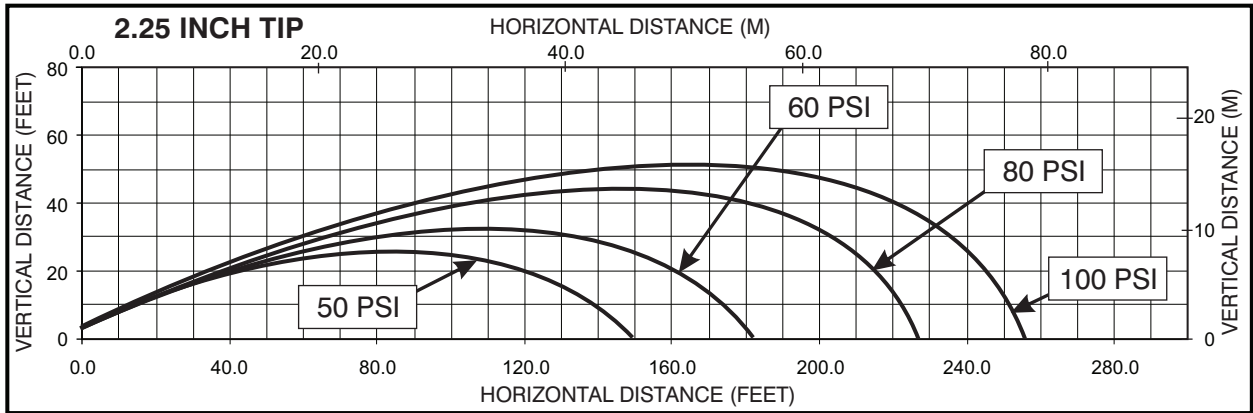
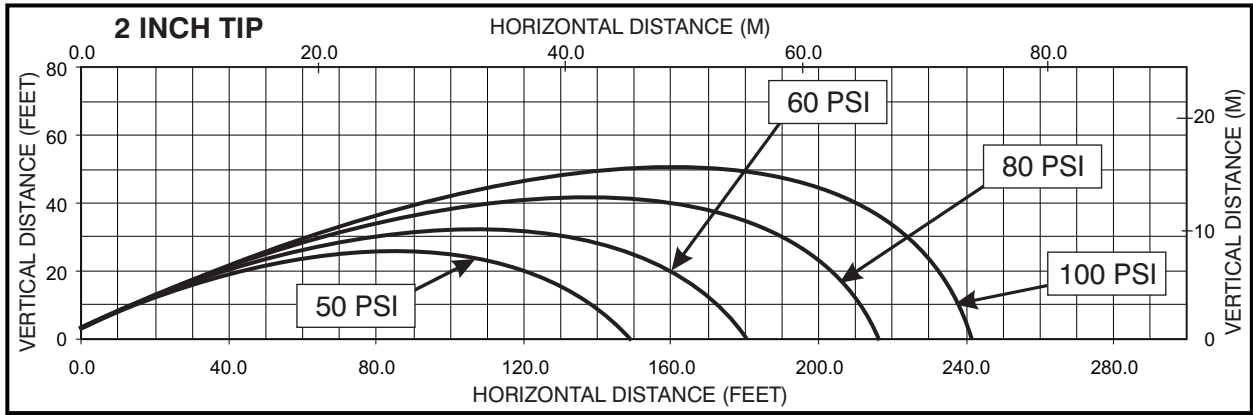

Figure 6.1C
YST-4NN Reach Graphs

6.2 MST-4NJ STACKED TIPS FLOW AND REACH

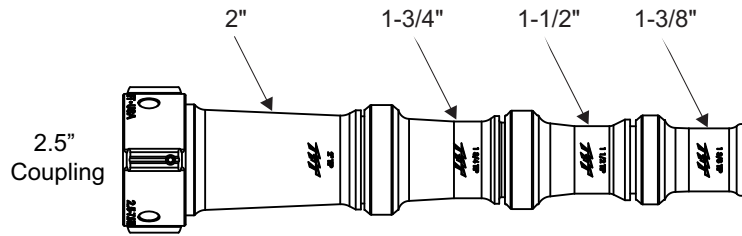

Figure 6.2A
Stacked Tip Model MST-4NJ

NOZZLE DIAMETER	NOZZLE INLET PRESSURE							
	40 PSI		60 PSI		80 PSI		100 PSI	
	FLOW (GPM)	REACTION (LBS)	FLOW (GPM)	REACTION (LBS)	FLOW (GPM)	REACTION (LBS)	FLOW (GPM)	REACTION (LBS)
1.375"	360	120	440	180	500	240	560	300
1.5"	420	140	520	210	500	280	670	350
1.75"	580	190	700	290	810	380	910	480
2.00"	750	250	920	380	1000	500	1190	630

NOZZLE DIAMETER	NOZZLE INLET PRESSURE							
	2.8 BAR		4.1 BAR		5.5 BAR		7 BAR	
	FLOW (L/min)	REACTION (KG)	FLOW (L/min)	REACTION (KG)	FLOW (L/min)	REACTION (KG)	FLOW (L/min)	REACTION (KG)
35 mm	1360	50	1670	80	1890	110	2120	140
38 mm	1590	60	1970	100	2270	130	2540	160
45 mm	2200	90	2650	130	3070	170	3440	220
50 mm	2840	110	3480	170	4010	230	4500	290

Table 6.2
MST-4NJ Flow and Reaction Force

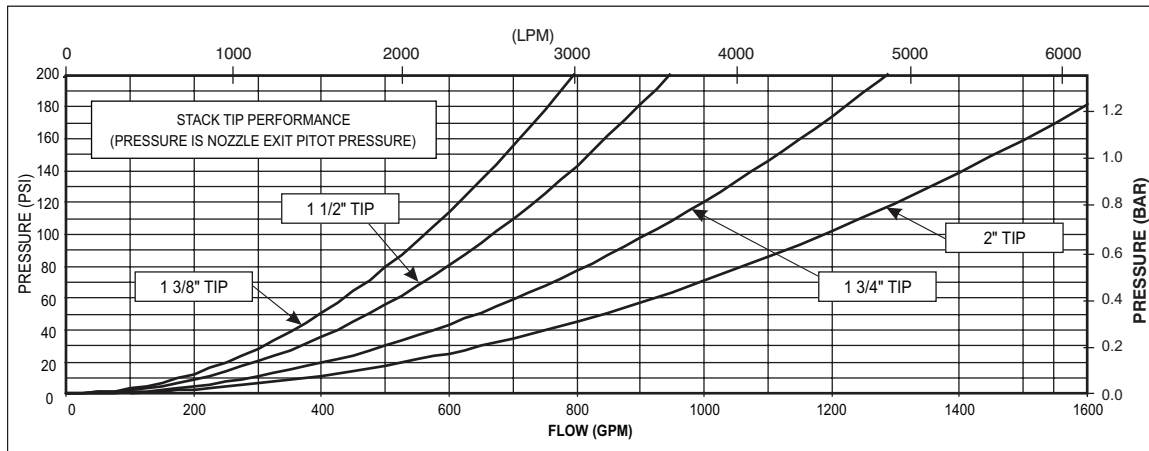

Figure 6.2B
MST-4NJ Flow Graph

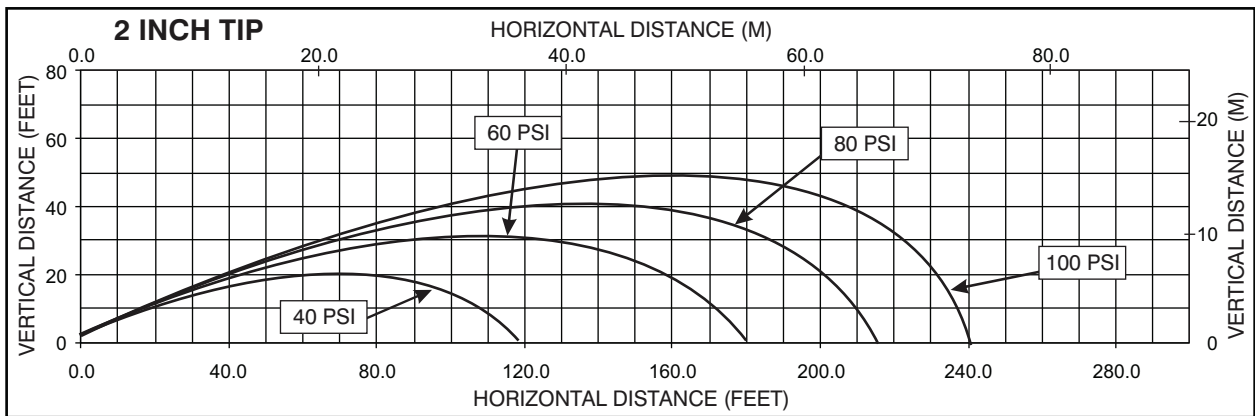
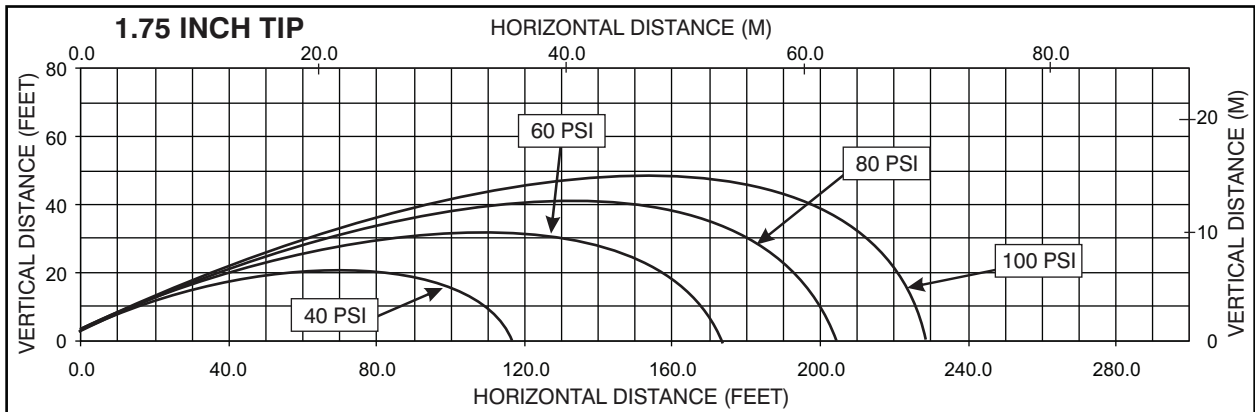
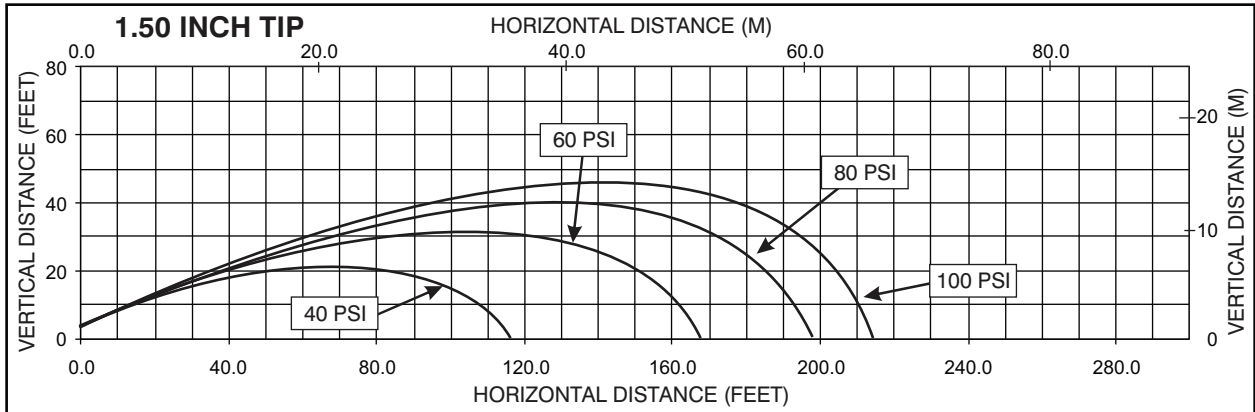
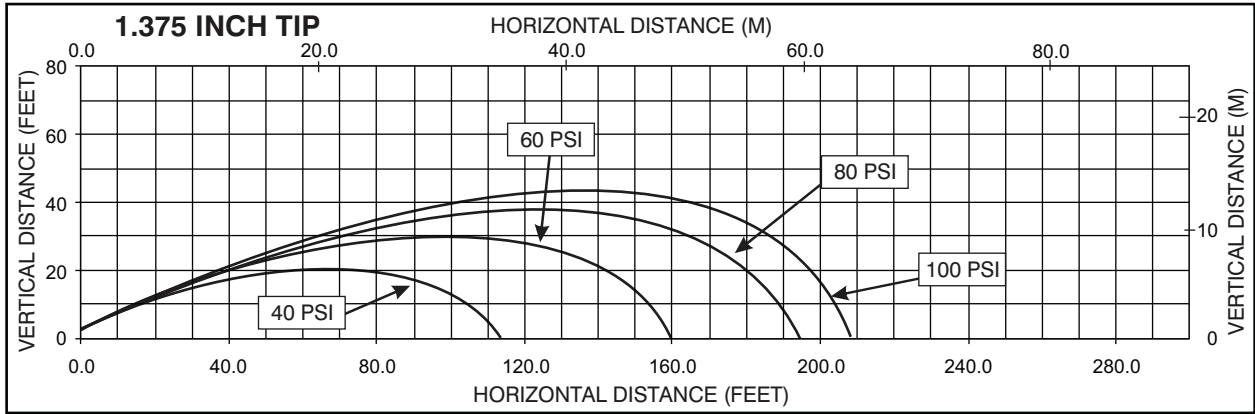

Figure 6.2C
MST-4NJ Reach Graphs

6.3 EFFECTS OF ELEVATION AND WIND ON STREAM REACH

This graph shows approximately how differences in elevation angle can affect stream reach. Critical applications should be tested in actual conditions to verify adequate reach.

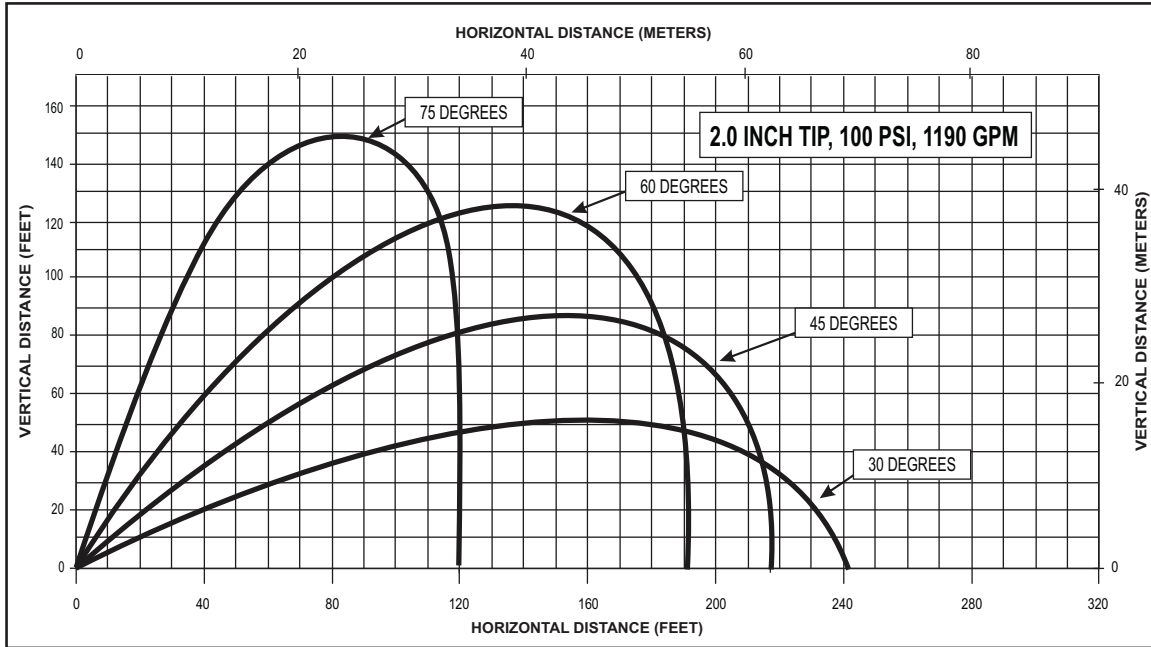

Figure 6.2A
Effects of Elevation on Reach

This graph shows approximately how a moderate wind can affect stream reach.

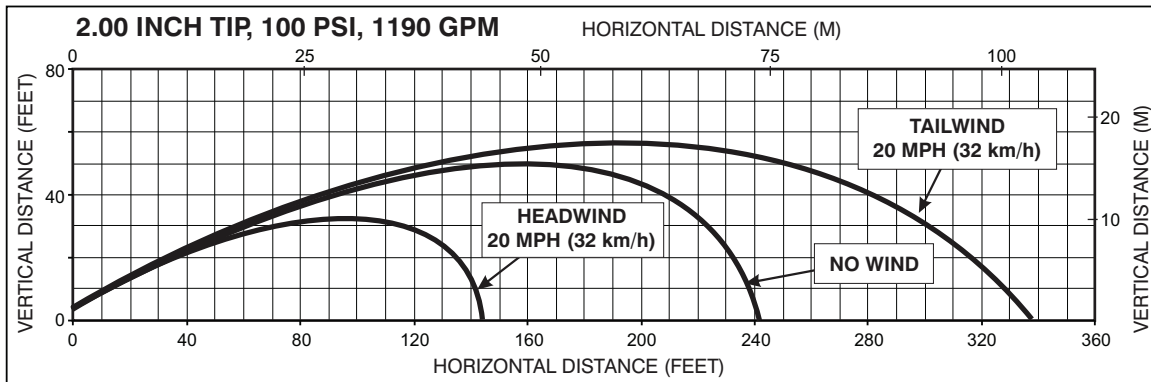

Figure 6.2B
Effects of Wind on Reach

6.4 AUTOMATIC MASTERSTREAM NOZZLES

Automatic nozzles maintain a constant pressure by adjusting their orifice to match the available flow. Consult the nozzle manufacturer for maximum flow and pressure range. In all cases, do not exceed the maximum rating of the FLEX Operating Envelope.

6.5 FRICTION LOSS

The discharge size of the monitor determines maximum flow. Excessive turbulence will result if maximum flow is exceeded.

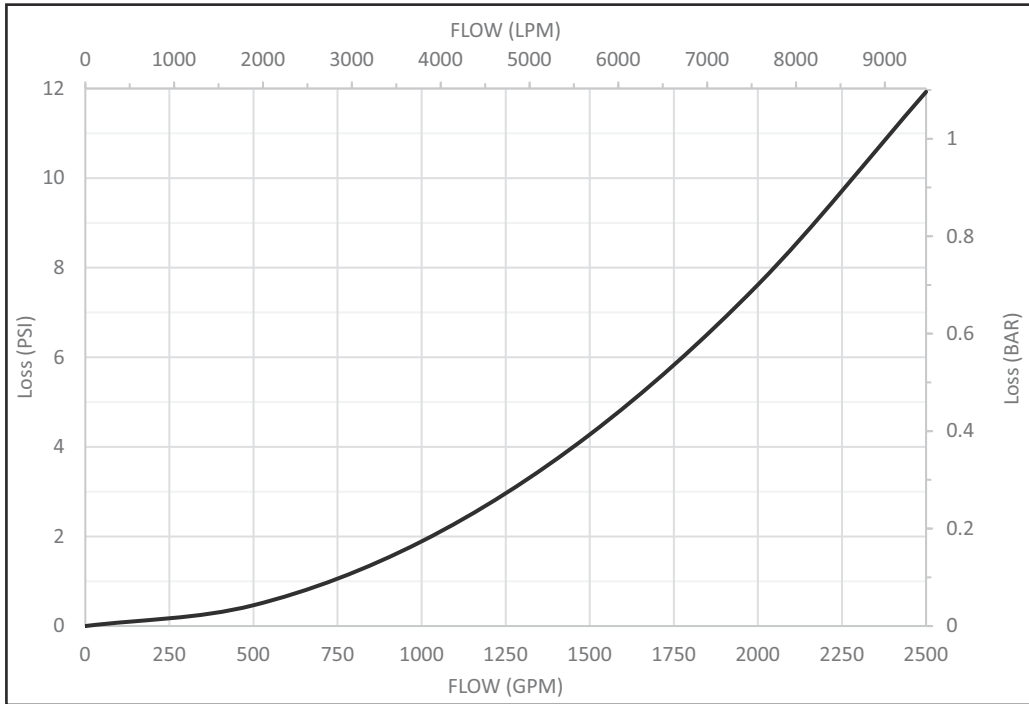

Figure 6.5A
FLEX Monitor Friction Loss

6.6 STREAM STRAIGHTENERS

6.6.1 STREAM STRAIGHTENERS WITH STACKED TIPS

Turbulence though the FLEX Monitor is very low, but stream quality and reach can be improved with the use of the integral stream straightener on the TFT stacked tip nozzle. Stream straighteners will add some friction loss as indicated below.

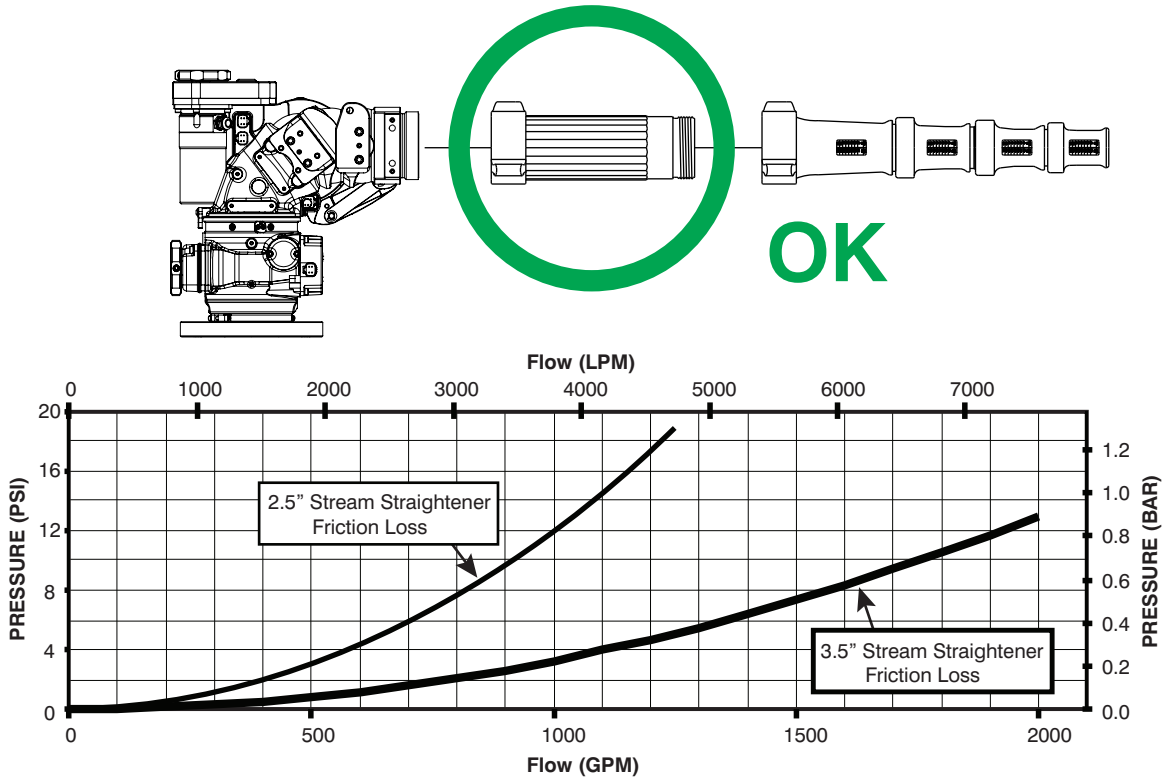

Figure 6.6.1

Stacked Tip Integral Stream Straightener Friction Loss

6.6.2 STREAM STRAIGHTENERS WITH FOG NOZZLES

NOTICE

The flow path of a fog nozzle serves as a stream straightener. Use of a stream straightener with a fog nozzle will increase the stresses on the monitor's gear train and may lead to premature wear. Use of a stream straightener with a fog nozzle is not recommended.

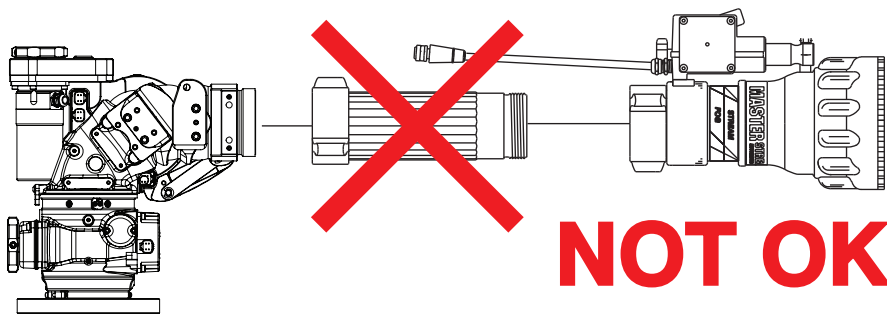

Figure 6.6.2

7.0 WARRANTY

Task Force Tips LLC, 3701 Innovation Way, Valparaiso, Indiana 46383-9327 USA ("TFT") warrants to the original purchaser of its products ("equipment"), and to anyone to whom it is transferred, that the equipment shall be free from defects in material and workmanship during the five (5) year period from the date of purchase for mechanical components, and the two (2) year period from the date of purchase for electrical components. TFT's obligation under this warranty is specifically limited to replacing or repairing the equipment (or its parts) which are shown by TFT's examination to be in a defective condition attributable to TFT. To qualify for this limited warranty, the claimant must return the equipment to TFT, at 3701 Innovation Way, Valparaiso, Indiana 46383-9327 USA, within a reasonable time after discovery of the defect. TFT will examine the equipment. If TFT determines that there is a defect attributable to it, TFT will correct the problem within a reasonable time. If the equipment is covered by this limited warranty, TFT will assume the expenses of repair.

If any defect attributable to TFT under this limited warranty cannot be reasonably cured by repair or replacement, TFT may elect to refund the purchase price of the equipment, less reasonable depreciation, in complete discharge of its obligations under this limited warranty. If TFT makes this election, claimant shall return the equipment to TFT free and clear of any liens and encumbrances.

This is a limited warranty. The original purchaser of the equipment, any person to whom it is transferred, and any person who is an intended or unintended beneficiary of the equipment, shall not be entitled to recover from TFT any consequential or incidental damages for injury to person and/or property resulting from any defective equipment manufactured or assembled by TFT.

It is agreed and understood that the price stated for the equipment is in part consideration for limiting TFT's liability. Some states do not allow the exclusion or limitation of incidental or consequential damages, so the above may not apply to you.

TFT shall have no obligation under this limited warranty if the equipment is, or has been, misused or neglected (including failure to provide reasonable maintenance) or if there have been accidents to the equipment or if it has been repaired or altered by someone else.

THIS IS A LIMITED EXPRESS WARRANTY ONLY. TFT EXPRESSLY DISCLAIMS WITH RESPECT TO THE EQUIPMENT ALL IMPLIED WARRANTIES OF MERCHANTABILITY AND ALL IMPLIED WARRANTIES OF FITNESS FOR A PARTICULAR PURPOSE. THERE IS NO WARRANTY OF ANY NATURE MADE BY TFT BEYOND THAT STATED IN THIS DOCUMENT.

This limited warranty gives you specific legal rights, and you may also have other rights which vary from state to state.

8.0 MAINTENANCE

TFT products are designed and manufactured to be damage resistant and require minimal maintenance. However, as the primary firefighting tool upon which your life depends, it should be treated accordingly. To help prevent mechanical damage, do not drop or throw equipment.

The unit should be kept clean and free of dirt by rinsing with water after each use. Any inoperable or damaged parts should be repaired or replaced before placing the unit in service.

In applications where appliances are left continuously connected to the apparatus or other devices or are used where water is trapped inside the appliance, the appliance must be flushed with fresh water following each use and inspected for damage.

This appliance should be disconnected, cleaned and visually inspected inside and out at least quarterly, or as water quality and use may require. Moving parts such as handles, valve ball and couplings should be checked for smooth and free operation. Seals shall be greased as needed with Silicone based grease such as Molykote 112. Any scrapes that expose bare aluminum on the casting portion of the unit should be cleaned and touched up with enamel paint such as Rust-Oleum. Any moving component on the outlet portion of the monitor should be paint free. Adding paint to this section may cause leakage or binding of the monitor.

Any equipment taken out of service due to failure should be returned to the factory for repair or replacement. If you have any questions regarding the testing or maintenance of your monitor, please call Task Force Tips at 800-348-2686.

8.1 SERVICE TESTING

In accordance with NFPA 1962, equipment must be tested a minimum of annually. Units failing any part of this test must be removed from service, repaired and retested upon completion of the repair.

8.2 LUBRICATION

The FLEX monitor generally should not require greasing. In the event that the operation becomes stiff, grease may be applied to the horizontal rotation and elevation worm gears. Grease is applied by removing the plugs at the grease ports and replacing with grease fittings that have 1/4-28 male threads. Use medium viscosity automotive chassis grease. Apply only enough grease to restore normal operation. If normal operation is not restored by greasing, inspect for other causes of stiff operation.

CAUTION Do not install grease in Tiller Models. Tiller models rely on friction to lock out the horizontal and vertical axis. Adding grease could comprise the locking capability of the monitor.

NOTICE Do not over pump grease. The monitor's greased areas lead to large chambers that could trap several pounds of grease before becoming visible.

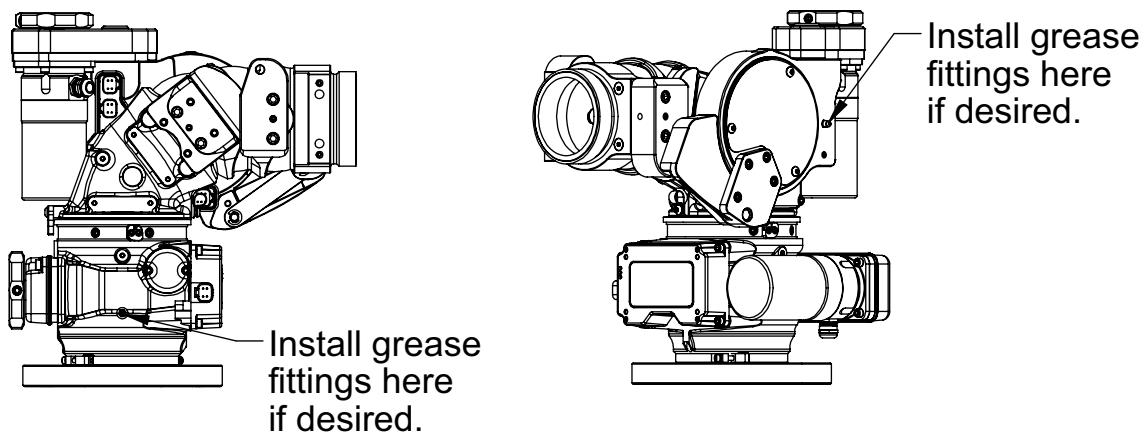

Figure 8.2
Grease Fitting Installation Locations

8.3 TROUBLESHOOTING

SYMPTOM	POSSIBLE CAUSE	REMEDY
Leaks	Debris or damage in the seal area	Clean out debris or replace damaged parts
Elevation Binding	Debris or damage to the elevation drive parts	Clean out debris or replace damaged parts
	Lack of lubricant	Grease, (see section 8.2)
Horizontal Rotation Binding	Debris or damage to the horizontal drive parts	Clean out debris or replace damaged parts
	Lack of lubricant	Grease, (see section 8.2)

8.4 REPAIR

Factory service is available. Factory serviced equipment is repaired by experienced technicians, wet tested to original specifications, and promptly returned. Call TFT service department at 1-800-348-2686 to troubleshoot and, if needed, directions for return. A return for service form can also be obtained at tft.com/Support/Returning-an-Item-for-Service.

Repair parts and service procedures are available for those wishing to perform their own repairs. Task Force Tips assumes no liability for damage to equipment or injury to personnel that is a result of user service. Contact the factory or visit the web site at tft.com for parts lists, exploded views, test procedures and troubleshooting guides.

Performance tests shall be conducted on the equipment after a repair, or anytime a problem is reported to verify operation in accordance with TFT test procedures. Consult factory for the procedure that corresponds to the model and serial number of the equipment. Any equipment which fails the related test criteria should be removed from service immediately. Troubleshooting guides are available with each test procedure or equipment can be returned to the factory for service and testing.

WARNING

It is the responsibility of service technicians to ensure the use of appropriate protective clothing and equipment. The chosen protective clothing and equipment must provide protection from potential hazards users may encounter while servicing equipment. Requirements for protective clothing and equipment are determined by the Authority Having Jurisdiction (AHJ).

CAUTION

Any alterations to the product or its markings could diminish safety and constitutes a misuse of this product.

NOTICE

All replacement parts must be obtained from the manufacturer to assure proper performance and operation of the device.

9.0 EXPLODED VIEWS AND PARTS LISTS

Exploded views and parts lists are available at tft.com/serial-number.

10.0 OPERATION AND INSPECTION CHECKLIST

BEFORE EACH USE, appliances must be inspected to this checklist:

1. All valves (if so equipped) open and close fully and smoothly
2. Waterway is clear of obstructions
3. There is no damage to any thread or other connection
4. All locks and hold-down devices work properly
5. The pressure setting on the relief valve (if so equipped) is set correctly
6. Gaskets are in good repair
7. There is no obvious damage such as missing, broken or loose parts
8. There is no damage to the appliance that could impair safe operation (e.g. dents, cracks, corrosion, or other defects)
9. All swiveling elements rotate freely
10. Nozzle is securely attached

BEFORE BEING PLACED BACK IN SERVICE, appliances must be inspected to this checklist:

1. All valves (if so equipped) open and close smoothly and fully
2. The waterway is clear of obstructions
3. There is no damage to any thread or other type connection
4. The pressure setting of the relief valve, if any, is set correctly
5. All locks and hold-down devices work properly
6. Internal gaskets are in accordance with NFPA 1962
7. There is no damage to the appliance that could impair safe operation (e.g. dents, cracks, corrosion, or other defects)
8. All swiveling connections rotate freely
9. There are no missing parts or components
10. The marking for maximum operating pressure is visible
11. There are no missing, broken, or worn lugs on couplings

NFPA 1962: Standard for the care, use, inspection, service testing, and replacement of fire hose, couplings, nozzles and fire hose appliances. Quincy, MA: National Fire Protection Agency

WARNING

Equipment failing any part of the checklist is unsafe for use and must have the problem corrected before use or being placed back into service. Operating equipment that has failed the checklist is a misuse of this equipment.

TASK FORCE TIPS LLC
MADE IN USA · tft.com

3701 Innovation Way, Valparaiso, IN 46383-9327 USA
800-348-2686 · 219-462-6161 · Fax 219-464-7155