

INSTRUCTIONS FOR INSTALLATION, SAFE OPERATION AND MAINTENANCE

⚠️ WARNING

Understand manual before use. Operation of this device without understanding the manual and receiving proper training is a misuse of this equipment. Obtain safety information at tft.com/serialnumber.

This equipment is intended for use by trained and qualified emergency services personnel for firefighting. All personnel using this equipment shall have completed a course of education approved by the Authority Having Jurisdiction (AHJ).

This instruction manual is intended to familiarize firefighters and maintenance personnel with the operation, servicing, and safety procedures associated with this product. This manual should be kept available to all operating and maintenance personnel.

ELECTRIC REMOTE OPERATED MODELS

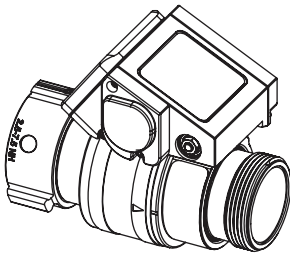

VORTEX 2 ER

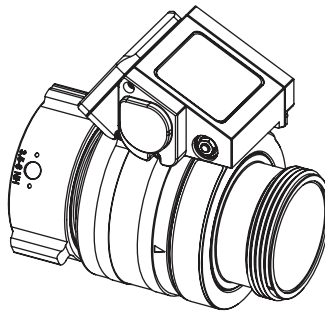

VORTEX 3 ER

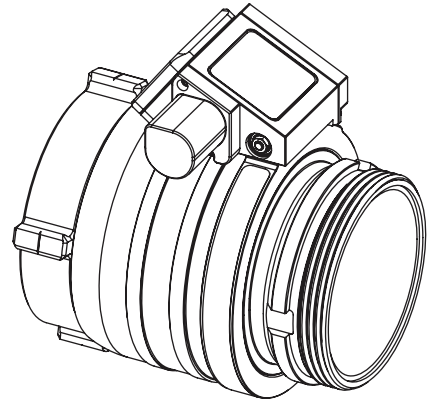

VORTEX 6 ER

MANUALLY OPERATED MODELS

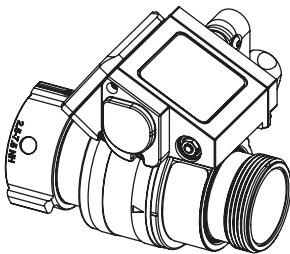

VORTEX 2

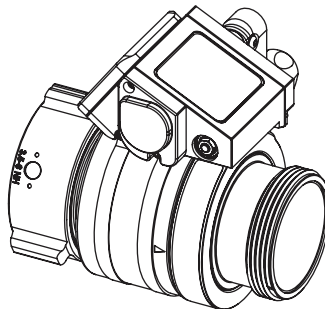

VORTEX 3



PERSONAL RESPONSIBILITY CODE

The member companies of FEMSA that provide emergency response equipment and services want responders to know and understand the following:

1. Firefighting and Emergency Response are inherently dangerous activities requiring proper training in their hazards and the use of extreme caution at all times.
2. It is your responsibility to read and understand any user's instructions, including purpose and limitations, provided with any piece of equipment you may be called upon to use.
3. It is your responsibility to know that you have been properly trained in Firefighting and /or Emergency Response and in the use, precautions, and care of any equipment you may be called upon to use.
4. It is your responsibility to be in proper physical condition and to maintain the personal skill level required to operate any equipment you may be called upon to use.
5. It is your responsibility to know that your equipment is in operable condition and has been maintained in accordance with the manufacturer's instructions.
6. Failure to follow these guidelines may result in death, burns or other severe injury.







Fire and Emergency Manufacturers and Service Association
P.O. Box 147, Lynnfield, MA 01940 • www.FEMSA.org

Table Of Contents









- 1.0 MEANING OF SAFETY SIGNAL WORDS
- 2.0 SAFETY
- 3.0 GENERAL INFORMATION
 - 3.1 VARIOUS MODELS AND TERMS
 - 3.2 SPECIFICATIONS
 - 3.3 NOZZLE COUPLINGS
 - 3.4 USE WITH SALT WATER
- 4.0 FLOW CHARACTERISTICS
 - 4.1 VORTEX 2 AND 2 ER FLOW CHARACTERISTICS AND CHARTS
 - 4.2 VORTEX 3 AND 3 ER FLOW CHARACTERISTICS AND CHARTS
 - 4.3 VORTEX 6 ER FLOW CHARACTERISTICS AND CHARTS
- 5.0 INSTALLATION
 - 5.1 VORTEX 2 AND 2 ER INSTALLATION
 - 5.2 VORTEX 3 AND 3 ER INSTALLATION
 - 5.2.1 VORTEX 3 AND 3 ER ORIENTATION
 - 5.3 VORTEX 6 ER INSTALLATION
- 6.0 OPERATION
- 7.0 USE WITH FOAM
- 8.0 USE OF NOZZLES
- 9.0 WARRANTY
- 10.0 MAINTENANCE
 - 10.1 FIELD LUBRICATION
 - 10.2 SERVICE TESTING
 - 10.3 REPAIR
- 11.0 DRAWINGS AND PART LISTS
- 12.0 OPERATION AND INSPECTION CHECKLIST

1.0 MEANING OF SAFETY SIGNAL WORDS

A safety related message is identified by a safety alert symbol and a signal word to indicate the level of risk involved with a particular hazard. Per ANSI Z535.6, the definitions of the four signal words are as follows:

- | | |
|--|---|
|  | DANGER indicates a hazardous situation which, if not avoided, will result in death or serious injury. |
|  | WARNING indicates a hazardous situation which, if not avoided, could result in death or serious injury. |
|  | CAUTION indicates a potentially hazardous situation which, if not avoided, could result in minor or moderate injury. |
|  | NOTICE is used to address practices not related to physical injury. |

2.0 SAFETY

- | | |
|--|---|
|  | An inadequate supply of pressure and/or flow will cause an ineffective stream and can result in injury or death. Choose operating conditions to deliver adequate fire suppression. See flow graphs |
|  | This equipment is intended for use by trained personnel for firefighting. Use of this equipment for other purposes may involve hazards not addressed by this manual. Seek appropriate guidance and training to reduce risk of injury |
|  | Equipment may be damaged if frozen while containing significant amounts of water. Such damage may be difficult to detect visually. Subsequent pressurization can lead to injury or death. Any time the equipment is subject to possible damage due to freezing, it must be tested and approved for use by qualified personnel before being considered safe for use. |
|  | This device is not rated as ignition proof, explosion proof, or intrinsically safe. Use only in locations with adequate ventilation and no hazard of flammable vapor buildup. |
|  | Application of water or foam solutions on energized electrical equipment could cause electrocution. Serious injury or death could result. Assume circuits are energized until confirmed to be de-energized. Do not apply water or foam to energized electrical equipment. |
|  | The stream exiting a nozzle is very powerful and capable of causing injury and property damage. Make sure the nozzle is securely attached and pointing in a safe direction before water is turned on. Do not direct water stream to cause injury or damage to persons or property. |
|  | Damage or injury could result from operating the monitor beyond the safe operating envelope. Do not operate the monitor outside the envelope in the following graph(s). |
|  | To prevent mechanical damage, do not drop or throw equipment. |

3.0 GENERAL INFORMATION

The TFT VORTEX Nozzles enhance the use of smooth bore nozzles. They are intended for installation behind a smooth bore nozzle for use with water or fire fighting foam solutions. Six short vanes in the bore of the VORTEX reduce turbulence in straight stream. Actuating a VORTEX nozzle from "STREAM" to "VORTEX" causes the vanes to pivot proportionally. This induces a gentle spin in the water to create a uniformly dispersed VORTEX stream pattern. The vanes are less obtrusive than a typical stream straightener, resulting in virtually no friction loss regardless of which stream pattern is selected. The vanes also allow large debris to easily pass through the VORTEX. Pattern selection is controlled with an electric drive on VORTEX ER nozzles. A manual actuation crank turned by hand is used to change the pattern on manually operated versions.

3.1 VARIOUS MODELS AND TERMS

VORTEX 2 and 2 ER models are configured with a 2.5" female coupling and 2.5" male threads on the outlet for use with stacked tips. VORTEX 3 and 3 ER models are configured with a 3.5" female coupling and 3.5" male threads on the outlet for use with stacked tips. VORTEX 6 ER models are configured with a 6"NH female fixed coupling and 6"NH male threads on the outlet for use with connecting to Tsunami Stacked Tips.

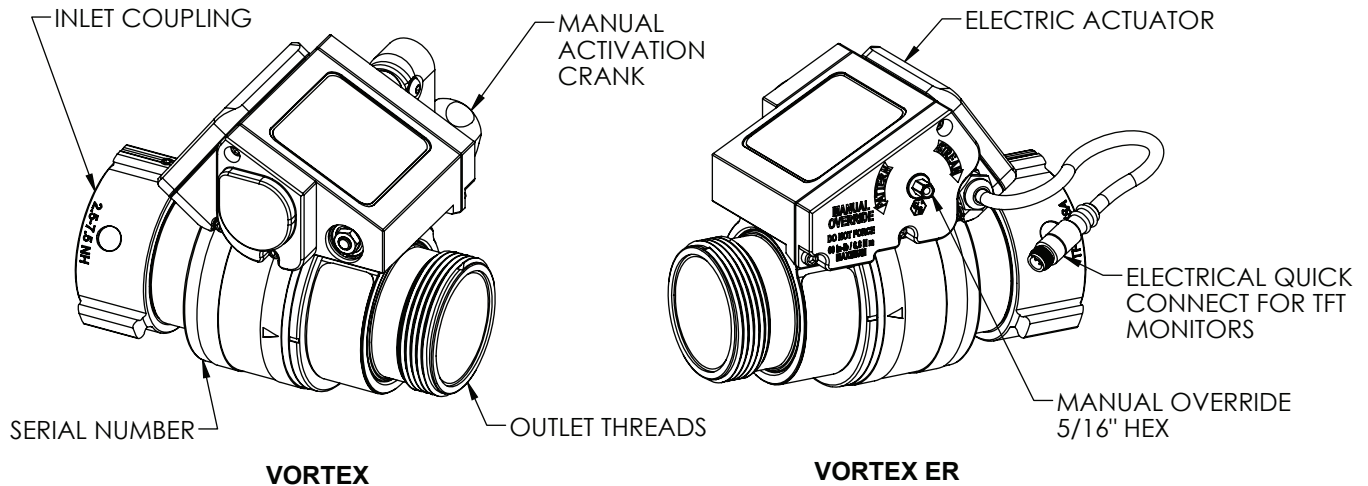

Figure 3.1

3.2 SPECIFICATIONS

	VORTEX 2 VORTEX 2 ER	VORTEX 3 VORTEX 3 ER	VORTEX 6 ER
Maximum Flow Rate	1250 gpm (4500 l/min)	2500 gpm (9500 l/min)	8000 gpm (30,000 l/min)
Maximum Operating Pressure	300 psi (21 bar)		
Hydrostatic Test Pressure	900 psi (62 bar)		
Actuation Time for Full Travel*	4 seconds	8 seconds	14 seconds
Electrical Requirements*	12V / 24V		
Waterway Diameter	2.5" (64 mm)	3.5" (89 mm)	6" (152 mm)
Standard Inlet/Outlet	2.5" NH, BSP, NPSH	2.5" NH, BSP, NPSH	6" NH
Overall Length	8.4" (213 mm)	9.0" (229 mm)	11" (279 mm)
Operating temperature of fluid	33° to 120°F (0° to 50°C)		
Storage temperature range	-40° to 150°F (-40° to 65°C)		
Materials used	Aluminum 6000 series hard anodized MIL8625 class 3 type 2, stainless steel 300 series, nitrile rubber		

* For ER Models Only

Figure 3.2

3.3 NOZZLE COUPLINGS

NH (National Hose Threads) threads are standard on all nozzles. Other threads such as NPSH (National Pipe Straight Hose) can be specified at time of order.



Mismatched or damaged waterway connections may cause equipment to leak or uncouple under pressure. Failure could result in injury. Equipment must be mated to matched connections.



Dissimilar metals coupled together can cause galvanic corrosion that can result in the inability to uncouple the connection, or complete loss of engagement over time. Failure could cause injury. Per NFPA 1962, if dissimilar metals are left coupled together, an anti-corrosive lubricant should be applied to the connection and the coupling should be disconnected and inspected at least quarterly.

3.4 USE WITH SALTWATER

Use with salt water is permissible provided the equipment is thoroughly cleaned with fresh water after each use. The service life of the equipment may be shortened due to the effects of corrosion, and is not covered under warranty.

4.0 FLOW CHARACTERISTICS

4.1 VORTEX 2 & 2 ER FLOW CHARACTERISTICS AND CHARTS

The VORTEX 2 & 2 ER has 2.5" (65mm) waterway integrated into the outlet. If a smaller smooth bore is attached to the outlet, follow the appropriate flow chart for the smaller orifice size instead.

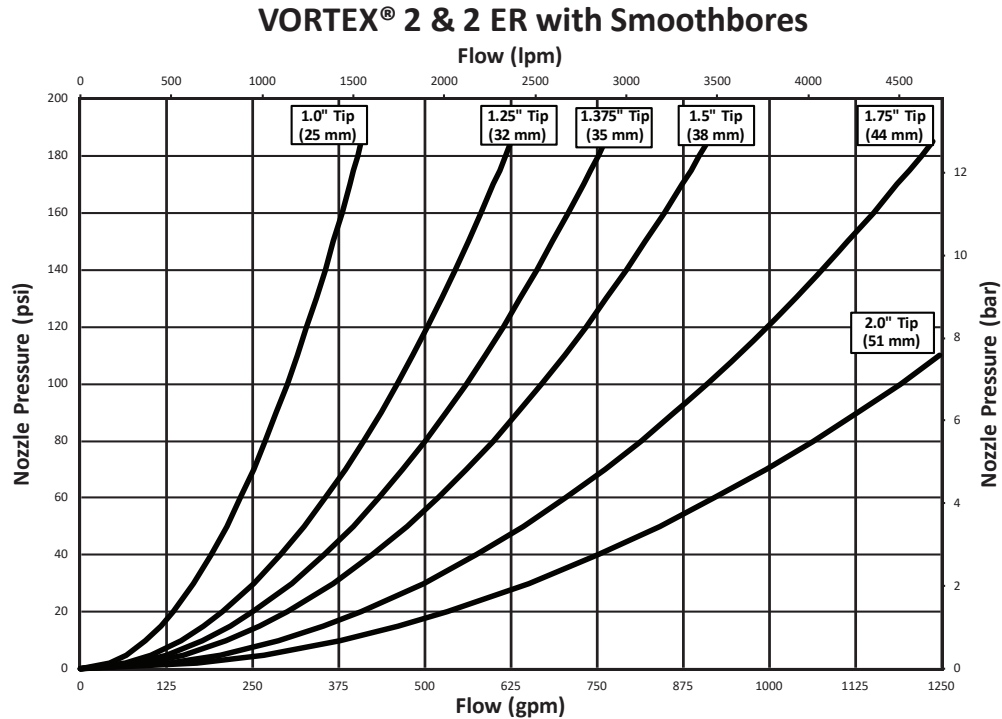

Figure 4.1

2.5" (65 mm) Stacked Tip Flow Tables

Nozzle Diameter (inches)	Nozzle Pressure (PSI)							
	50		60		80		100	
	Flow GPM	Reaction lbf	Flow GPM	Reaction lbf	Flow GPM	Reaction lbf	Flow GPM	Reaction lbf
1	210	79	230	94	266	126	297	157
1.25	328	123	360	147	415	196	464	245
1.375	397	148	435	178	502	237	562	297
1.5	473	177	518	212	598	283	668	353
1.75	643	240	705	288	814	385	910	481
2	840	314	921	377	1063	502	1188	628

Nozzle Diameter (mm)	Nozzle Pressure (BAR)							
	3.5		4.1		5.5		7	
	Flow LPM	Reaction kgf	Flow LPM	Reaction kgf	Flow LPM	Reaction kgf	Flow LPM	Reaction kgf
25	795	36	871	43	1007	57	1124	71
32	1242	56	1363	67	1571	89	1756	111
35	1503	67	1647	81	1900	108	2127	135
38	1790	80	1961	96	2264	128	2529	160
44	2434	109	2669	131	3081	175	3445	218
51	3180	142	3486	171	4024	228	4497	285

Table 4.1

4.2 VORTEX 3 AND 3 ER FLOW CHARACTERISTICS AND CHARTS

The VORTEX 3 & 3 ER has a 3.5" (89mm) waterway integrated into the outlet. If a smaller smoothbore is attached to the outlet, follow the appropriate flow chart for the smaller orifice size instead.

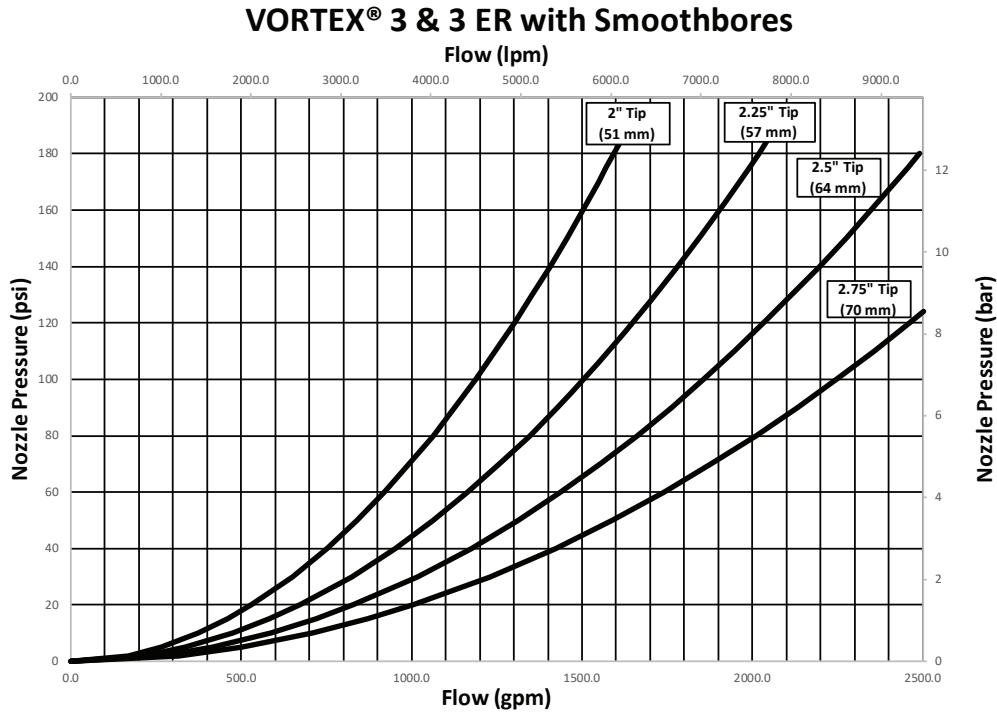

Figure 4.2

3.5" (89 mm) Stacked Tip Flow Tables

Nozzle Diameter (inches)	Nozzle Pressure (PSI)							
	50		60		80		100	
	Flow GPM	Reaction lbf	Flow GPM	Reaction lbf	Flow GPM	Reaction lbf	Flow GPM	Reaction lbf
2	840	314	921	377	1063	502	1188	628
2.25	1064	397	1165	477	1345	636	1504	795
2.5	1313	491	1438	589	1661	785	1857	981
2.75	1589	594	1740	712	2010	950	2247	1187

Nozzle Diameter (mm)	Nozzle Pressure (BAR)							
	3.5		4.1		5.5		7	
	Flow LPM	Reaction kgf	Flow LPM	Reaction kgf	Flow LPM	Reaction kgf	Flow LPM	Reaction kgf
51	1380	142	3486	171	4024	228	4479	285
57	4028	180	4410	216	5091	288	5693	361
64	4970	223	5443	276	6288	356	7030	445
70	6015	269	6587	323	7609	431	8506	539

Table 4.2

4.3 VORTEX 6 ER FLOW CHARACTERISTICS AND CHARTS

The VORTEX 6 ER has a 6" (157mm) waterway integrated into the outlet. If a smaller smoothbore is attached to the outlet, follow the appropriate flow chart for the smaller orifice size instead.

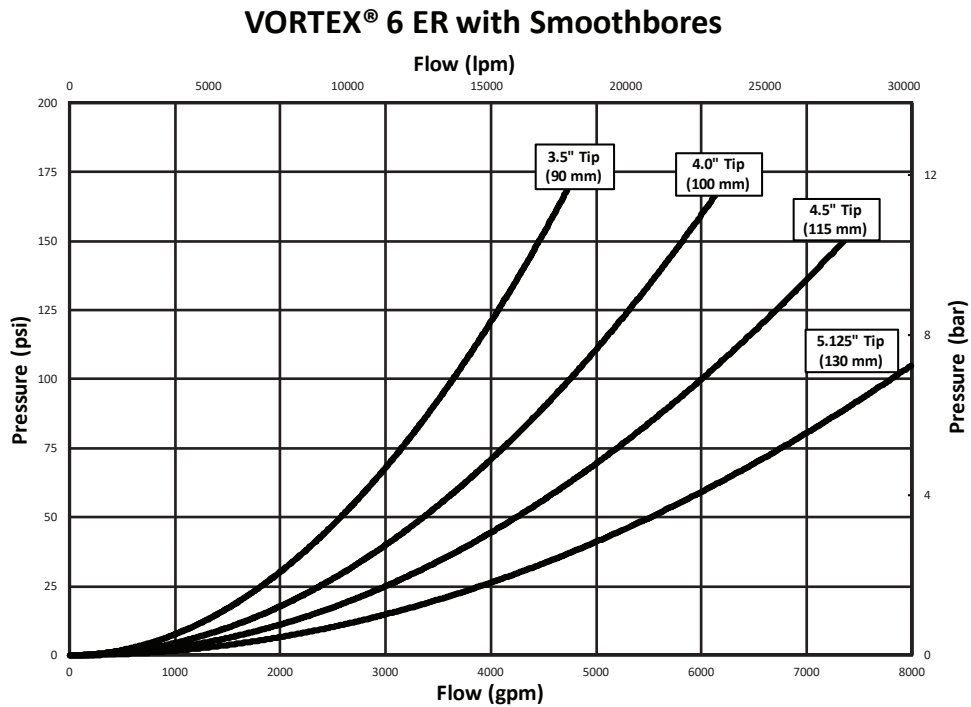

Figure 4.3

6" (157 mm) Stacked Tip Flow Tables

Nozzle Diameter (inches)	Nozzle Pressure (PSI)							
	50		60		80		100	
	Flow GPM	Reaction lbf	Flow GPM	Reaction lbf	Flow GPM	Reaction lbf	Flow GPM	Reaction lbf
3.5	2570	960	2820	1160	3260	1540	3640	1930
4	3360	1260	3680	1510	4250	2010	4750	2510
4.5	4250	1590	4660	1910	5380	2550	6020	3180
5.125	5520	2060	6040	2470	6980	3300	7800	4130

Nozzle Diameter (mm)	Nozzle Pressure (BAR)							
	3.5		4.1		5.5		7	
	Flow LPM	Reaction kgf	Flow LPM	Reaction kgf	Flow LPM	Reaction kgf	Flow LPM	Reaction kgf
90	9730	440	10670	530	12340	700	13780	880
100	12720	570	13930	690	16090	910	17980	1140
115	16090	720	17640	870	20360	1160	22790	1450
130	20890	940	22860	1120	26420	1500	29520	1880

Table 4.3

5.0 INSTALLATION

NOTICE

Installing a stream straightener after the VORTEX will disrupt the dispersed pattern and produce poor stream quality.

5.1 VORTEX 2 & 2 ER INSTALLATION

The VORTEX 2 & VORTEX 2 ER is intended to be installed on the outlet of a monitor and paired with stacked tips or smooth bores.

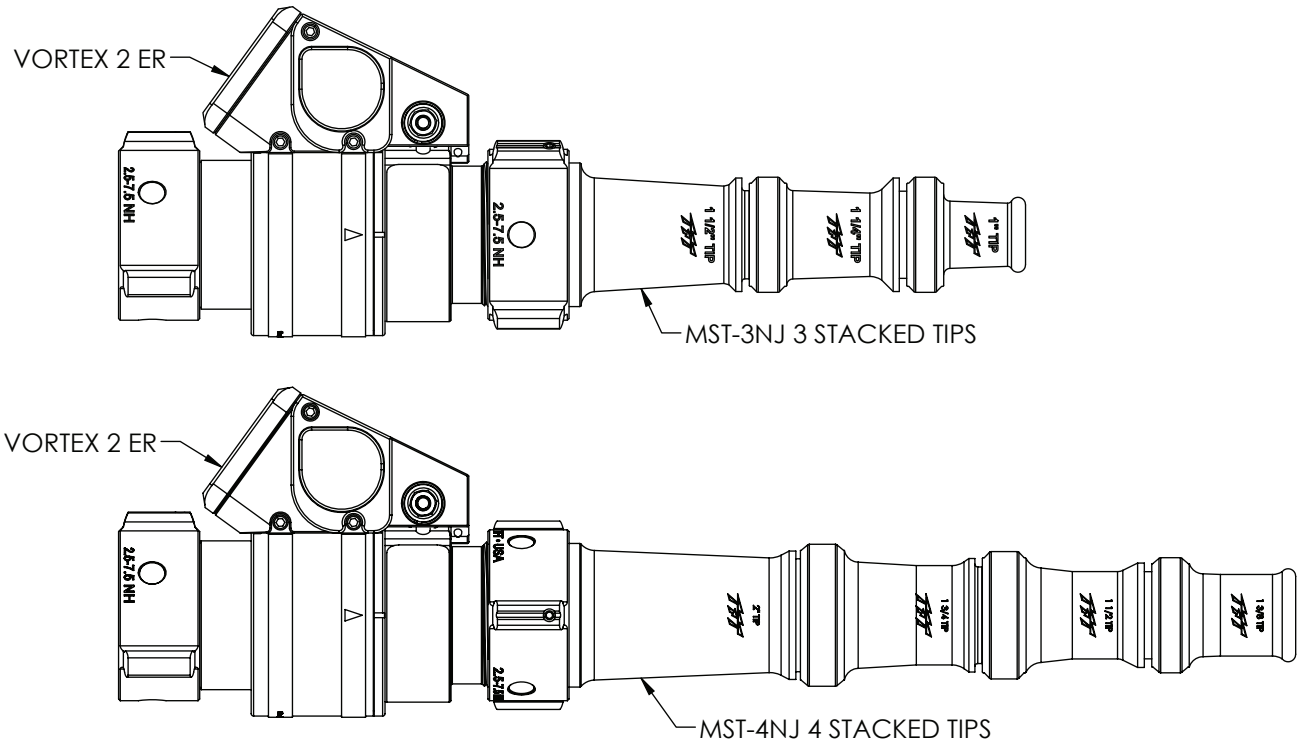

Figure 5.1

5.2 VORTEX 3 AND 3 ER INSTALLATION

The VORTEX 3 & VORTEX 3 ER is intended to be installed on the outlet of a monitor and paired with stacked tips or smooth bores.

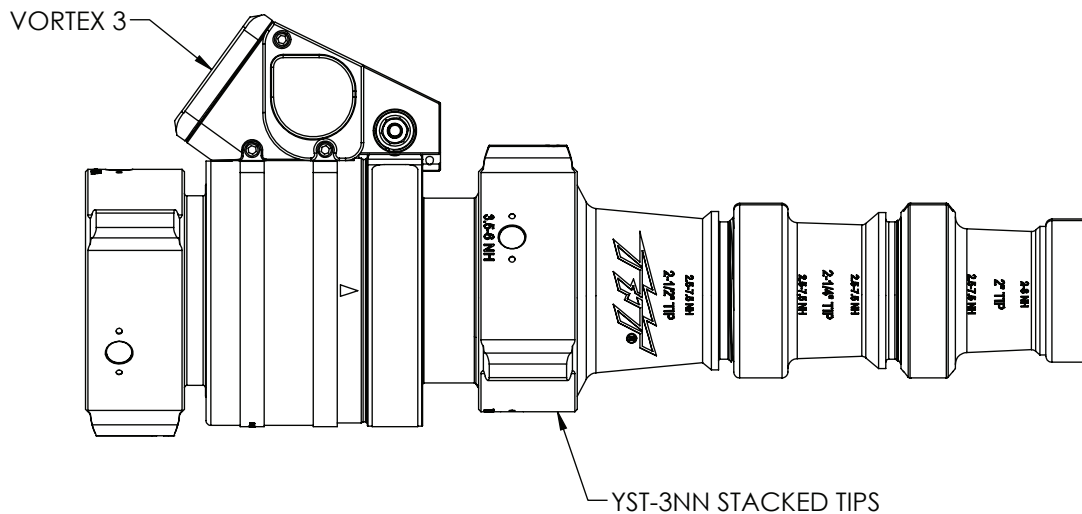
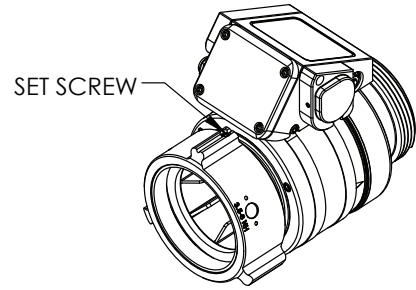

Figure 5.2

5.2.1 VORTEX 3 AND 3 ER ORIENTATION

The coupling on the VORTEX 3 or 3 ER is locked to the body. Once installed on the monitor, the orientation of the VORTEX can be changed to position the motor housing appropriately for your installation. Instructions to orient the VORTEX are shown below.

1. Thread the VORTEX 3 on the monitor just until the gasket starts to compress.
2. Back the set screw out (2) turns using a 5/32" hex key
3. Turn the VORTEX until it is oriented to the desired position.
4. Tighten the set screw to 45 in-lb.
5. Fully tighten the Vortex on the monitor.



CAUTION Failure to tighten the set screw may allow the VORTEX to spin on it's coupling while flowing water in the dispersed VORTEX pattern. Free spinning could result in injury or equipment damage. Set screw must be tightened to 45 in-lb.

5.3 VORTEX 6 ER INSTALLATION

The VORTEX 6 ER is intended to be installed in place of the straight section of the YST-8NX Tsunami Stacked Tips and paired with stacked tips or smooth bores.

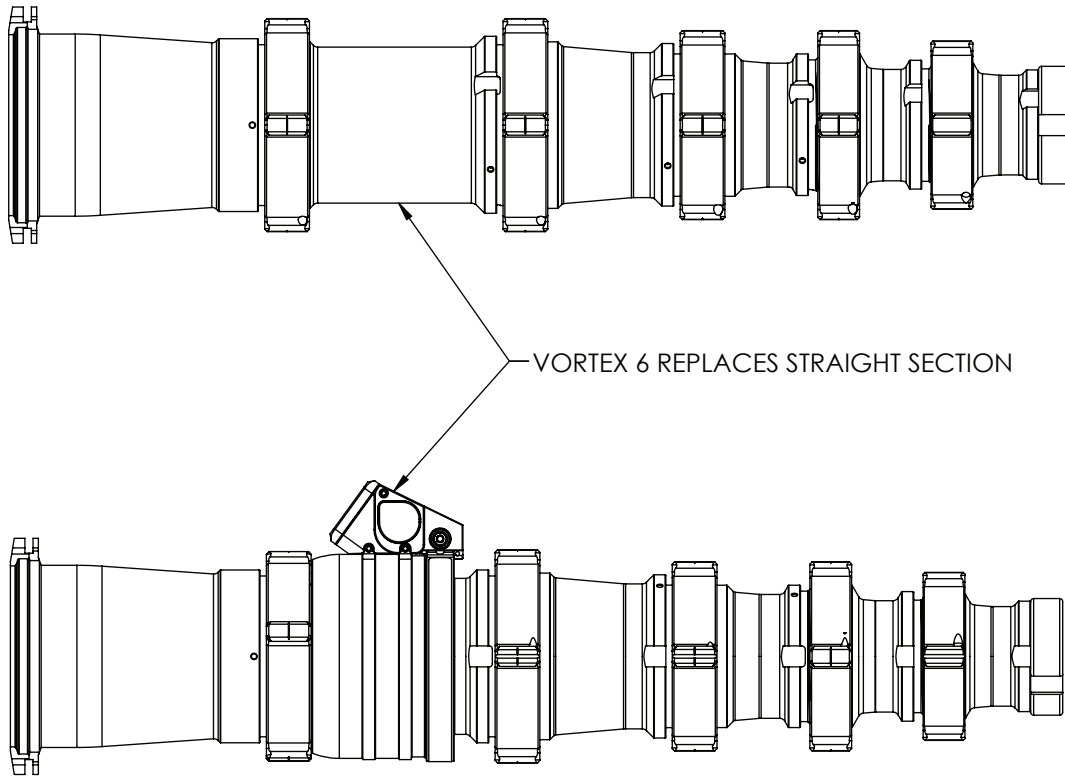

Figure 5.3

6.0 OPERATION

The TFT VORTEX Nozzle allow the stream pattern to be infinitely varied from a straight stream to a uniformly dispersed VORTEX pattern. Typical stream results are shown in Figure 6.0A.

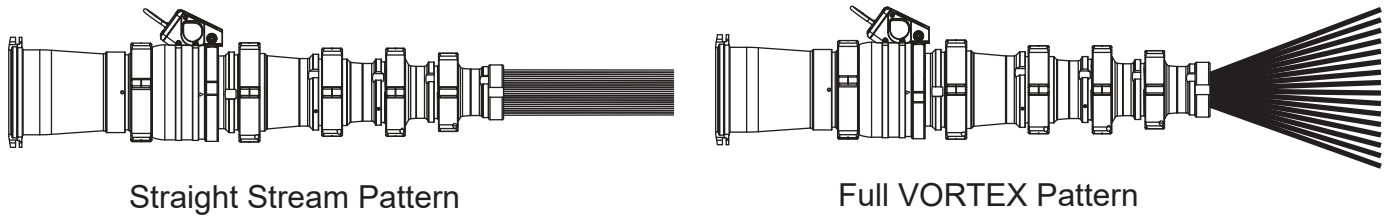

Figure 6.0A

The VORTEX includes a label indicator for the user to confirm when the VORTEX is at the straight stream or in a VORTEX dispersed position. As seen from the operating position behind the nozzle, actuating the VORTEX indicator counterclockwise moves into the straight stream position. Actuating the VORTEX indicator clockwise will result in an increasingly wider pattern until reaching the full VORTEX pattern.

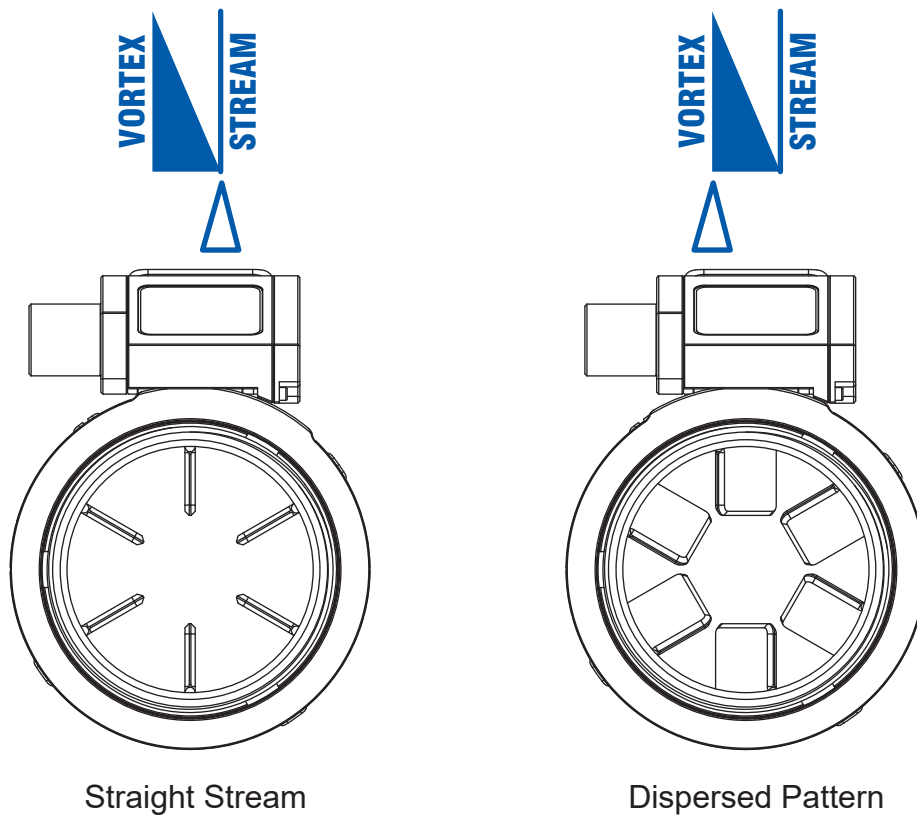

Figure 6.0B

Pivoting the vanes has virtually no effect on the flow area or ability to pass large debris. As a result, discharge pressure and flow rate remain constant regardless of stream pattern.

Manual override is possible on ER models by using the 5/16" hex head to drive the motor shaft. Manual versions include a crank for actuating the VORTEX. Turning the shaft clockwise moves the nozzle towards a straight stream pattern. Turning the shaft counterclockwise moves the nozzle to the dispersed VORTEX spray pattern. Do not force the shaft further after it stops firmly at each end of stroke. Exceeding 60 in-lb (6.8 N·m) can damage the actuator.

CAUTION

The electric drives are current limited but may still produce enough force to cause injury. To avoid injury from a moving monitor:

- Be aware that the monitor may be remotely operated
- Keep hands and fingers away from pinch points on the monitor
- Never operate the manual override while electric controls are in operation

7.0 USE WITH FOAM

The nozzle may be used with foam solutions. Refer to fire service training for the proper use of foam.



WARNING

For Class B fires, lack of foam or interruption in the foam stream can cause a break in the foam blanket and greatly increase the risk of injury or death. Follow procedures established by the AHJ for the specific fuel and conditions.



WARNING

Improper use of foam or using the wrong type of foam can result in illness, injury, or damage to the environment. Follow foam manufacturer's instructions and fire service training as directed by the AHJ.

8.0 USE OF NOZZLES

IT IS THE RESPONSIBILITY OF THE INDIVIDUAL FIRE DEPARTMENT OR AGENCY TO DETERMINE PHYSICAL CAPABILITIES AND SUITABILITY FOR AN INDIVIDUAL'S USE OF THIS EQUIPMENT.

Many factors contribute to the extinguishment of a fire. Among the most important is delivering water at a flow rate sufficient to absorb heat faster than it is being generated. The flow rate depends largely on the pump discharge pressure and hose friction loss. It can be calculated using a hydraulic equation such as:

$$PDP = NP + FL + DL + EL$$

- PDP = Pump discharge pressure in PSI
- NP = Nozzle pressure in PSI
- FL = Hose friction loss in PSI
- DL = Device loss in PSI
- EL = Elevation loss in PSI

This Safety Manual is not intended as a substitute for proper training in the use of rescue systems as taught from credible sources such as the National Fire Protection Association (NFPA), the International Fire Service Training Association (IFSTA), or sources approved by the Authority Having Jurisdiction (AHJ).

9.0 WARRANTY

Task Force Tips LLC, 3701 Innovation Way, Valparaiso, Indiana 46383-9327 USA (“TFT”) warrants to the original purchaser of its products (“equipment”), and to anyone to whom it is transferred, that the equipment shall be free from defects in material and workmanship during the five (5) year period from the date of purchase.

TFT’s obligation under this warranty is specifically limited to replacing or repairing the equipment (or its parts) which are shown by TFT’s examination to be in a defective condition attributable to TFT. To qualify for this limited warranty, the claimant must return the equipment to TFT, at 3701 Innovation Way, Valparaiso, Indiana 46383-9327 USA, within a reasonable time after discovery of the defect. TFT will examine the equipment. If TFT determines that there is a defect attributable to it, TFT will correct the problem within a reasonable time. If the equipment is covered by this limited warranty, TFT will assume the expenses of repair.

If any defect attributable to TFT under this limited warranty cannot be reasonably cured by repair or replacement, TFT may elect to refund the purchase price of the equipment, less reasonable depreciation, in complete discharge of its obligations under this limited warranty. If TFT makes this election, claimant shall return the equipment to TFT free and clear of any liens and encumbrances.

This is a limited warranty. The original purchaser of the equipment, any person to whom it is transferred, and any person who is an intended or unintended beneficiary of the equipment, shall not be entitled to recover from TFT any consequential or incidental damages for injury to person and/or property resulting from any defective equipment manufactured or assembled by TFT. It is agreed and understood that the price stated for the equipment is in part consideration for limiting TFT’s liability. Some states do not allow the exclusion or limitation of incidental or consequential damages, so the above may not apply to you.

TFT shall have no obligation under this limited warranty if the equipment is, or has been, misused or neglected (including failure to provide reasonable maintenance) or if there have been accidents to the equipment or if it has been repaired or altered by someone else.

THIS IS A LIMITED EXPRESS WARRANTY ONLY. TFT EXPRESSLY DISCLAIMS WITH RESPECT TO THE EQUIPMENT ALL IMPLIED WARRANTIES OF MERCHANTABILITY AND ALL IMPLIED WARRANTIES OF FITNESS FOR A PARTICULAR PURPOSE. THERE IS NO WARRANTY OF ANY NATURE MADE BY TFT BEYOND THAT STATED IN THIS DOCUMENT.

This limited warranty gives you specific legal rights, and you may also have other rights which vary from state to state.

10.0 MAINTENANCE

TFT products are designed and manufactured to be damage resistant and require minimal maintenance. However, as the primary firefighting tool upon which your life depends, it should be treated accordingly. To help prevent mechanical damage, do not drop or throw equipment.

10.1 FIELD LUBRICATION

All Task Force Tips nozzles are factory lubricated with high quality silicone grease. This lubricant has excellent wash out resistance, providing long term performance in firefighting nozzles. If your department has unusually hard or sandy water, the moving parts of the nozzle may be affected. Foam agents and water additives contain soaps and chemicals that may break down the factory lubrication. The moving parts of the nozzle should be checked on a regular basis for smooth and free operation, and for signs of damage. IF THE NOZZLE IS OPERATING CORRECTLY, THEN NO ADDITIONAL LUBRICANT IS NEEDED. Any nozzle that is not operating correctly should be immediately removed from service. The nozzle can be returned to the factory at any time for a complete checkup and relubrication with silicone grease.

The field use of Break Free CLP (spray or liquid) lubricant will help to temporarily restore the smooth and free operation of the nozzle. These lubricants do not have the washout resistance and long-term performance of the silicone grease. Once Break Free CLP is applied, re-application will be needed on a regular basis until the nozzle can be returned to the factory for a complete checkup and relubrication with silicone grease.

CAUTION Aerosol lubricants contain solvents that can swell O-Rings if applied in excess. The swelling can inhibit smooth operation of the moving parts. When used in moderation, as directed, the solvents quickly evaporate without adversely swelling the O-Rings.

10.2 SERVICE TESTING

In accordance with NFPA 1962, equipment must be tested a minimum of annually. Units failing any part of this test must be removed from service, repaired and retested upon completion of the repair.

10.3 REPAIR

Factory service is available with repair time seldom exceeding one day in our facility. Factory serviced equipment is repaired by experienced technicians, wet tested to original specifications, and promptly returned. Repair charges for non-warranty items are minimal. Any returns should include a note as to the nature of the problem and whom to reach in case of questions.

Repair parts and service procedures are available for those wishing to perform their own repairs. Task Force Tips assumes no liability for damage to equipment or injury to personnel that is a result of user service. Contact the factory or visit the web site at tft.com for parts lists, exploded views, test procedures and troubleshooting guides. All replacement parts must be obtained from the manufacturer to assure proper operation of the product, and to maintain approval of the device.

Performance tests shall be conducted on the equipment after a repair, or anytime a problem is reported to verify operation in accordance with TFT test procedures. Consult factory for the procedure that corresponds to the model and serial number of the equipment. Any equipment which fails the related test criteria should be removed from service immediately. Troubleshooting guides are available with each test procedure or equipment can be returned to the factory for service and testing.

CAUTION Any alterations to the product or its markings could diminish safety and constitutes a misuse of this product.

11.0 DRAWINGS AND PART LISTS

Exploded View Drawings and Part Lists for all VORTEX products are found at tft.com/serial-number.

12.0 OPERATION AND INSPECTION CHECKLIST

BEFORE EACH USE, *equipment must be inspected to this checklist:*

1. There is no obvious damage such as missing, broken or loose parts, damaged labels, etc.
2. Internal vanes are free of debris
3. Coupling is tight and leak free
4. Nozzle flow is adequate as indicated by pump pressure and nozzle reaction
5. Nozzle turns freely and adjusts pattern through full range with electric and manual control

BEFORE BEING PLACED BACK IN SERVICE, equipment must be inspected to this list:

1. All controls and adjustments are operational.
2. There are no broken or missing parts.
3. There is no damage that could impair safe operation (e.g. detents, cracks, corrosion, or other defects).
4. The gasket is in good condition
5. The waterway is clear of obstructions
6. The equipment is clean and markings are legible
7. Coupling is retightened properly
8. Nozzle is set to the desired pattern



Equipment failing any part of the checklist is unsafe for use and must have the problem corrected before use or being placed back into service. Operating equipment that has failed the checklist is a misuse of this equipment.