

## INSTRUCTIONS FOR SAFE OPERATION AND MAINTENANCE

### ⚠ WARNING

Understand manual before use. Operation of this device without understanding the manual and receiving proper training is a misuse of this equipment. Obtain safety information at [www.tft.com/serial-number](http://www.tft.com/serial-number)

### ⚠ WARNING

This equipment is intended for use by trained personnel for firefighting. Their use for other purposes may involve hazards not addressed by this manual. Seek appropriate guidance and training to reduce risk of injury.

This instruction manual is intended to familiarize firefighters and maintenance personnel with the operation, servicing and safety procedures associated with the Transformer Nozzle System.

This manual should be kept available to all operating and maintenance personnel.

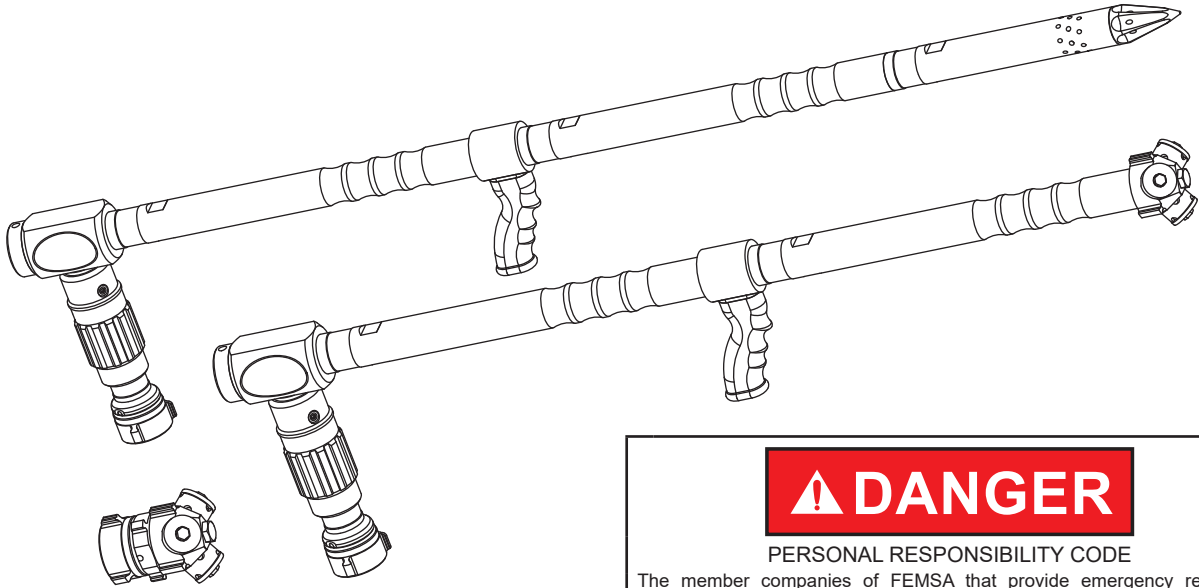

**Nominal Rated Flow**  
**150 GPM @ 100 PSI**  
**(570 l/min @ 7 bar)**  
**Maximum Operating Pressure**  
**300 psi (20 bar)**

### ⚠ DANGER

#### PERSONAL RESPONSIBILITY CODE

The member companies of FEMSA that provide emergency response equipment and services want responders to know and understand the following:

1. Firefighting and Emergency Response are inherently dangerous activities requiring proper training in their hazards and the use of extreme caution at all times.
2. It is your responsibility to read and understand any user's instructions, including purpose and limitations, provided with any piece of equipment you may be called upon to use.
3. It is your responsibility to know that you have been properly trained in Firefighting and /or Emergency Response and in the use, precautions, and care of any equipment you may be called upon to use.
4. It is your responsibility to be in proper physical condition and to maintain the personal skill level required to operate any equipment you may be called upon to use.
5. It is your responsibility to know that your equipment is in operable condition and has been maintained in accordance with the manufacturer's instructions.
6. Failure to follow these guidelines may result in death, burns or other severe injury.



Fire and Emergency Manufacturers and Service Association  
P.O. Box 147, Lynnfield, MA 01940 • [www.FEMSA.org](http://www.FEMSA.org)

## TABLE OF CONTENTS

1.0	MEANING OF SAFETY SIGNAL WORDS	6.0	FIREGROUND USE
2.0	GENERAL INFORMATION	7.0	WARRANTY
3.0	SAFETY	8.0	EXPLODED VIEW AND PARTS LIST
4.0	USE WITH SALT WATER	9.0	INSPECTION AND MAINTENANCE
5.0	FOAM USAGE		

### 1.0 MEANING OF SAFETY SIGNAL WORDS

A safety related message is identified by a safety alert symbol and a signal word to indicate the level of risk involved with a particular hazard. Per ANSI standard Z535.6-2011, the definitions of the four signal words are as follows:



**DANGER** indicates a hazardous situation which, if not avoided, will result in death or serious injury.



**WARNING** indicates a hazardous situation which, if not avoided, could result in death or serious injury.



**CAUTION** indicates a potentially hazardous situation which, if not avoided, may result in minor or moderate injury.



**NOTICE** is used to address practices not related to physical injury.

### 2.0 GENERAL INFORMATION

The Task Force Tips Transformer Nozzle System allows delivery of water or foam solutions to locations inaccessible to firefighters using standard nozzles. Transformer Nozzles consist primarily of hard coated extruded aluminum and features a hardened stainless steel point. A series of jets in and near the tip apply a wide reaching spherical flow. A swivel coupling with 1.5" NH (38mm) female hose thread is standard (National Hose Threads per NFPA #1963).

The Transformer design puts an emphasis on versatility, light weight, and small package. The use of aluminum tubing and threaded joints allowed TFT to create a unique lightweight product. The primary goal of this project was to develop a tool that could deliver high water flow rates into tight spaces with a wide range of stream types. In every design compromises must be made. While the transformer can penetrate thin sheet metal such as would be found on a mobile home or drywall and siding found on a typical home it is NOT intended to be a primary forcible entry tool. If during an emergency situation where it becomes necessary to drive the Transformer thru heavy plywood, steel sheeting or roofing materials it should be EXPECTED that some damage will occur. It is also expected that tools used in emergency services have some level of expendability as compared to the property they are purchased to protect. The Transformer was sized such that it will fit thru the hole created by the pick of a typical fire axe. After the hole is made with the axe the axe should be rotated about the axis of the point to round and open the hole for the entry of the transformer. Repeated training with the Transformer where it is hammered thru difficult materials WILL result in damage to the device and is not a part of the product warranty.

Each Transformer Nozzle System comes equipped with a unique rotary shutoff valve. The rotary shutoff valve allows the user to operate the Transformer Nozzle System Package without an additional shutoff valve. Operation of the rotary shutoff valve is simple. From the OFF position, a quarter turn to the left fully opens the waterway. To stop water flow from the ON position, turn the rotary shutoff valve a quarter turn to the right. Do not operate the Transformer Nozzle System with the rotary shutoff valve in the intermediate position between ON and OFF. If not in the ON or OFF position, the rotary shutoff valve may change position unexpectedly.

The Transformer Nozzle System uses a separate striking head. Install the striking head in one of the three threaded holes on the junction block.

Hand tighten the striking head assembly into the chosen port. Turn the striking cap, by hand, beyond the initial contact with the junction block to load the junction block spring. The spring loaded striking cap stays secure in the junction block and protects the threads from damage.

Due to the modular construction of the Transformer Nozzle System, the user may configure the nozzle in different arrangements to suit the situation. Additional components are available from the manufacturer to further customize the Transformer Nozzle System.

The Task Force Tips Distributor Nozzle distributes water droplets over a large area. Three spinners create an interference pattern of water droplets for a dense water pattern. The distributor nozzle attaches to the Transformer Nozzle System and provides additional flexibility to the operator. Distributor nozzles couple to fire hose via an adapter with a 1.5" NH (37 mm) female full time swivel inlet (National Hose Threads per NFPA #1963). When operated, a distributor nozzle provides a nominal water flow of 150 GPM at 100 PSI (560 l/min at 7 bar). The distributor nozzle's primary construction consists of aluminum and stainless steel.

## 2.0 GENERAL INFORMATION (continued)

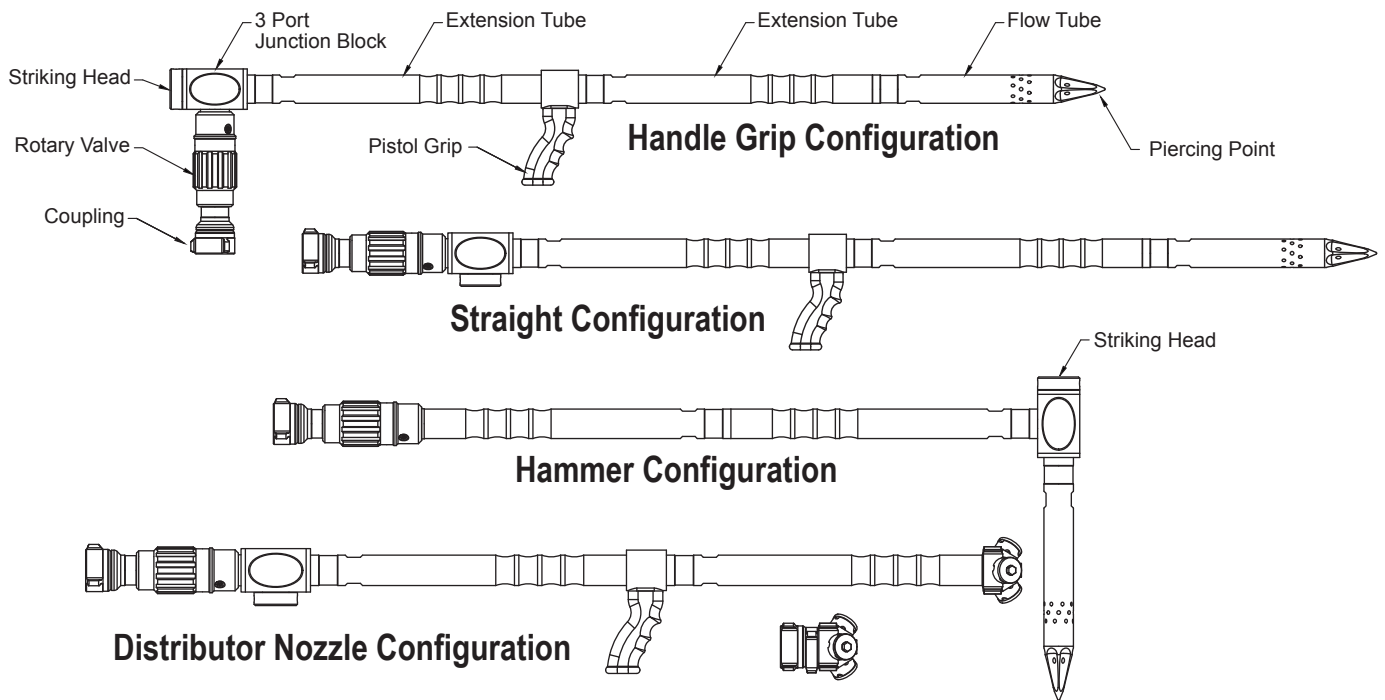

Figure 2.0 Part Identification

### **⚠ DANGER**

An inadequate supply of nozzle pressure and/or flow will cause an ineffective stream and can result in injury, death or loss of property. The recommended flow and pressure for the Transformer Nozzle System is 150 gpm at 100 psi. Call 800-348- 2686 for assistance.

### **⚠ WARNING**

Do not attempt to assemble, disassemble, or configure the Transformer Nozzle System with a pressurized fire hose attached. Safely depressurize and remove the fire hose prior to any assembly or disassembly of the Transformer Nozzle System.

### **⚠ WARNING**

Misaligned, loose, or damaged threads may cause the threaded joints to uncouple under pressure resulting in injury. Nozzle joints must be properly connected. Ensure the threaded joints between components are completely installed and hand tightened.

### **⚠ WARNING**

The piercing point has sharp edges that can cause injury by impalement. Use care when handling and striking the Transformer Nozzle. Do not use the Transformer as a pry bar under any circumstance. Avoid laying the tool down or storing in a position that presents an impalement or fall hazard.

### **⚠ WARNING**

Striking the Transformer Nozzle System with a sledge or ax creates risk of injury from missed blows. Always wear protective fire gear, eye protection, and gloves. Avoid holding the Transformer Nozzle System in areas likely to be struck by a missed blow. Avoid standing in the path of a swinging tool head. Avoid striking the Transformer Nozzle System when fatigued beyond one's ability to safely control a swing. Exercise sound judgement when operating on sloped, elevated, or slippery surfaces.

### **⚠ CAUTION**

The Transformer Nozzle System is designed only to hit on the striking head. Striking in any other location is considered abuse and resulting damage is not covered under warranty.

### **NOTICE**

**ONLY HAND TIGHTEN THE TRANSFORMER NOZZLE SYSTEM THREADED JOINT. DO NOT USE A WRENCH TO ASSEMBLE THE TRANSFORMER NOZZLE SYSTEM.**

### **NOTICE**

Use of the Transformer Nozzle System as a lever or a wedge may cause the unit to bend or fracture. Such damage is considered abuse. The resulting damage is not covered under warranty.

### **NOTICE**

Do not use the distributor nozzle to penetrate obstacles. Always create access points with appropriate tools.

### 3.0 SAFETY

#### **⚠️ WARNING**

Water is a conductor of electricity. Application of water and/or foam solutions on energized electrical equipment can cause injury or death by electrocution. The amount of current that may be carried back to the nozzle will depend on the following factors:

- Voltage of the line or equipment
- Distance from the nozzle to the line or equipment
- Size of the stream
- Whether the stream is solid or broken
- Purity of the water

The Fire Fighter and Electrical Equipment, The University of Michigan Extension Service, Fourth Printing 1983. Page 47.

#### **⚠️ WARNING**

**Risk of electrocution! Penetrating a wall or barrier may place the Nozzle System in direct metal to metal contact with electric wiring and equipment which can cause injury or death by electrocution. The nozzle and water are both conductors of electricity. Assume that all wires are energized at lethal levels. Always disable electric service prior to penetrating hidden spaces.**

#### **⚠️ WARNING**

If nozzle gets out of control or away from operator, retreat from nozzle immediately. Do not attempt to regain control of nozzle while flowing water. Injury from whipping can occur.

#### **⚠️ WARNING**

Walking on weakened roofs, floors, and decks increases risk of falling thru the structure to areas below which may be engulfed by flame. Exercise sound judgement when operating on questionable surfaces.

#### **⚠️ WARNING**

Large amounts or pieces of debris can reduce the flow of the nozzle resulting in an ineffective flow. In the event of a blockage, it may be necessary to retreat to a safe area, uncouple nozzle and remove debris.

#### **⚠️ CAUTION**

Water streams are capable of injury and damage. Do not direct water stream to cause injury or damage to persons or property.

#### **⚠️ CAUTION**

Nozzle reaction will vary as supply conditions change: such as opening or closing other nozzles, hoseline kinks, changes in pump settings, etc. The nozzle operator must always be prepared in the event of those changes. Failure to restrain nozzle reaction can cause firefighter injury from loss of footing and/or stream protection.

#### **⚠️ CAUTION**

Kinks in hose line may reduce water flow and cause injury or death to persons dependent on water flow. Avoid tight bends to minimize risk of hoseline kinks.

#### **⚠️ CAUTION**

Quick changes in valve position can cause high pressure spikes due to water hammer and may result in damaged equipment which could lead to injury or death. Open and close the valve slowly to avoid water hammer.

### 4.0 USE WITH SALT WATER

Use with salt water is permissible provided nozzle is thoroughly cleaned with fresh water after each use. The service life of the nozzle may be shortened due to the effects of corrosion and is not covered under warranty.

### 5.0 FOAM USAGE

The Task Force Tips Transformer Nozzle System is suitable for use with Class A foam, especially when hidden hot spots need to be soaked. Generally, the reach with foam is approximately 10 % less than with water only. Actual results will vary based on brand of foam, hardness of water, temperature, etc. Always flush the nozzle thoroughly with water after foam use.

#### Assure that:

- Application rate is sufficient (see NFPA 11 or foam manufacturer's recommendations).
- Enough concentrate is on hand to complete task (see NFPA for minimum duration time requirements).
- Foam logistics have been carefully planned. Allow for such things as:
  - Storage of foam in a location not exposed to the hazard it protects.
  - Personnel, equipment and technique to deliver foam at a rapid enough rate.
  - Removal of empty foam containers.
  - Keeping clear path to deliver foam as hoses, other equipment and vehicles are deployed.

#### **⚠️ WARNING**

**Improper use of foam can result in injury or damage to the environment. Follow foam manufacturer's instructions and fire service training to avoid:**

- Using wrong type of foam on a fire, i.e. Class A foam on a Class B fire.
- Plunging foam into pools of burning liquid fuels.
- Causing environmental damage.
- Directing stream at personnel.

#### **⚠️ WARNING**

There is a wide variety of foam concentrates. Each user is responsible for verifying that any foam concentrate chosen to be used with this unit has been tested to assure that the foam obtained is suitable for the purpose intended.

## 6.0 FIREGROUND USE

IT IS THE RESPONSIBILITY OF THE INDIVIDUAL FIRE DEPARTMENT OR AGENCY TO DETERMINE PHYSICAL CAPABILITIES AND SUITABILITY FOR AN INDIVIDUAL'S USE OF THIS EQUIPMENT.

### **NOTICE**

Many factors contribute to the extinguishment of a fire. Among the most important is delivering water at a flow rate sufficient to absorb heat faster than is being generated. The flow rate depends largely on the pump discharge pressure and hose friction loss.

Friction loss can be calculated using a hydraulic equation such as:

$$\text{PDP} = \text{NP} + \text{FL} + \text{DL} + \text{EL}$$

PDP = Pump discharge pressure in PSI

NP = Nozzle pressure in PSI

FL = Hose friction loss in PSI

DL = Device loss in PSI

EL = Elevation loss in PSI

The Transformer Nozzle System's estimated device loss is between 30 and 40 PSI (2 to 3 Bar) for most configurations. For additional information on calculating specific hose layouts, consult an appropriate fire-service training manual, A Firefighters Guide to Nozzles published by Task Force Tips, or call TFT's "Hydraulics Hotline" at 800-348-2686, request document #LTT-010.

## 7.0 WARRANTY

Task Force Tips LLC, 3701 Innovation Way, Valparaiso, IN 46383-9327 USA ("TFT") warrants to the original purchaser of its Nozzle System ("equipment"), and to anyone to whom it is transferred, that the equipment shall be free from defects in material and workmanship during the five (5) year period from the date of purchase.

TFT's obligation under this warranty is specifically limited to replacing or repairing the equipment (or its parts) which are shown by TFT's examination to be in a defective condition attributable to TFT. To qualify for this limited warranty, the claimant must return the equipment to TFT, at 3701 Innovation Way, Valparaiso, IN 46383-9327 USA, within a reasonable time after discovery of the defect. TFT will examine the equipment. If TFT determines that there is a defect attributable to it, TFT will correct the problem within a reasonable time. If the equipment is covered by this limited warranty, TFT will assume the expenses of repair.

If any defect attributable to TFT under this limited warranty cannot be reasonably cured by repair or replacement, TFT may elect to refund the purchase price of the equipment, less reasonable depreciation, in complete discharge of its obligations under this limited warranty. If TFT makes this election, claimant shall return the equipment to TFT free and clear of any liens and encumbrances.

This is a limited warranty. The original purchaser of the equipment, any person to whom it is transferred, and any person who is an intended or unintended beneficiary of the equipment, shall not be entitled to recover from TFT any consequential or incidental damages for injury to person and/or property resulting from any defective equipment manufactured or assembled by TFT. It is agreed and understood that the price stated for the equipment is in part consideration for limiting TFT's liability. Some states do not allow the exclusion or limitation of incidental or consequential damages, so the above may not apply to you.

TFT shall have no obligation under this limited warranty if the equipment is, or has been, misused or neglected (including failure to provide reasonable maintenance) or if there have been accidents to the equipment or if it has been repaired or altered by someone else.

**THIS IS A LIMITED EXPRESS WARRANTY ONLY. TFT EXPRESSLY DISCLAIMS WITH RESPECT TO THE EQUIPMENT ALL IMPLIED WARRANTIES OF MERCHANTABILITY AND ALL IMPLIED WARRANTIES OF FITNESS FOR A PARTICULAR PURPOSE. THERE IS NO WARRANTY OF ANY NATURE MADE BY TFT BEYOND THAT STATED IN THIS DOCUMENT.**

This limited warranty gives you specific legal rights, and you may also have other rights which vary from state to state.

# 8.0 EXPLODED VIEW AND PARTS LIST

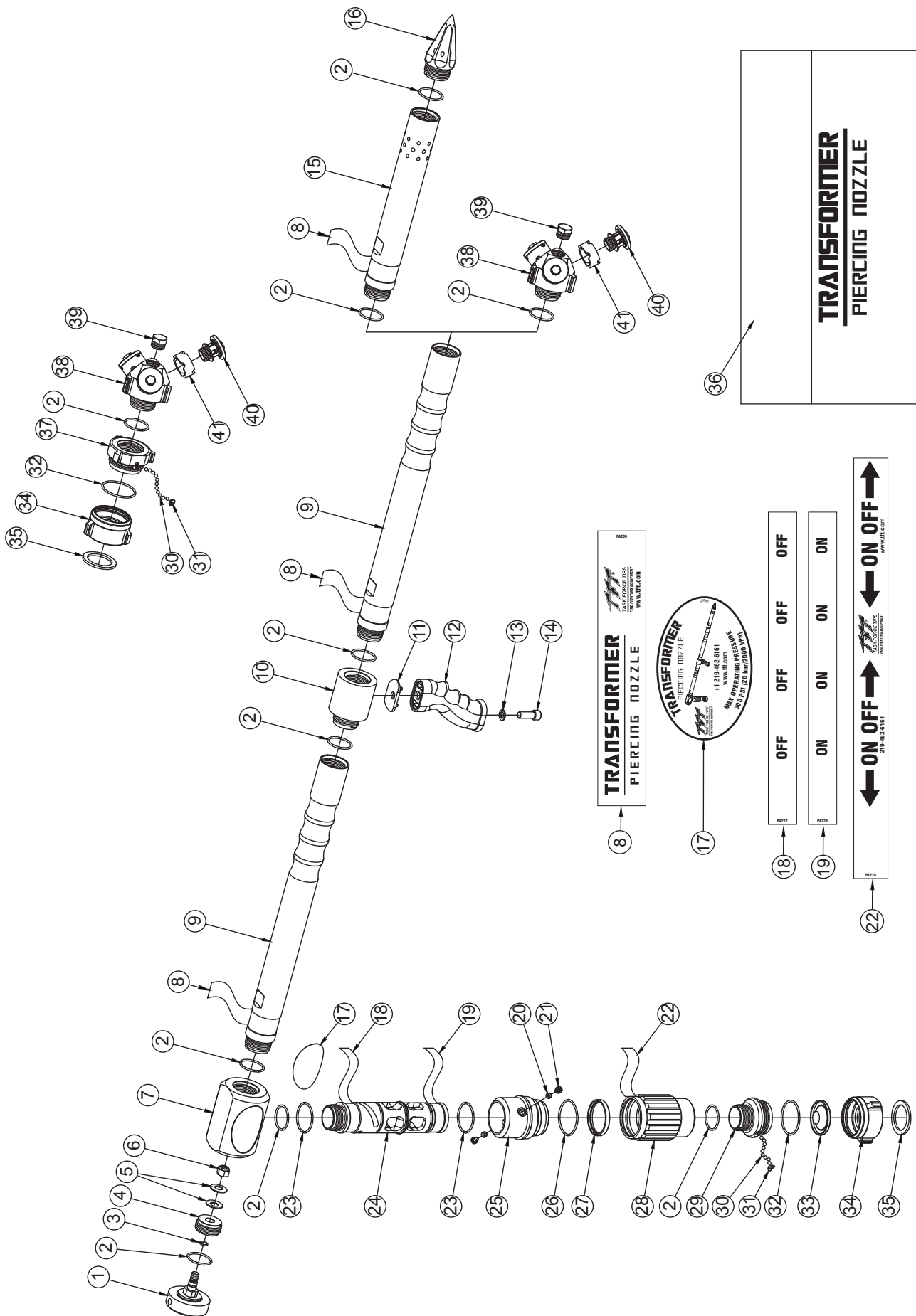

## PARTS LIST

INDEX	DESCRIPTION	QTY.	PART
1	PIERCING NOZZLE STRIKING CAP	1	PA161
2	O-RING-125	9	VO-125
3	O-RING-012	1	VO-012
4	PIERCING NOZZLE STRIKING PLUG	1	PA162
5	BELLEVILLE WASHER	2	VM4903
6	7/16-14 NYLOCK HEX NUT	1	VT43-14LNT
7	3 PORT JUNCTION BLOCK	1	PA150
8	LABEL: BRAND	3	PA206
9	19" EXTENSION TUBE	2	PA110
	40" EXTENSION TUBE	1	PA170
	12" EXTENSION TUBE	1	PA230
10	GRIP MOUNT	1	PA250
11	GRIP SPACER	1	HM693-F
12	PISTOL GRIP - BLACK	1	HM692-BLK
13	WASHER	1	VM4901
14	3/8-16 X 1 SOCKET HEAD SCREW	1	VT37-16SH1.0
15	FLOW PATTERN EXTENSION SECTION	1	PA120
	LOW FLOW PATTERN EXTENSION SECTION	1	PA120L
16	PIERCING POINT	1	PA141
17	NAME LABEL: TRANSFORMER PIERCING NOZZLE	2	PA205
18	LABEL: ROTARY VALVE OFF - RED	1	PA227
19	LABEL: ROTARY VALVE ON - BLUE	1	PA226
20	FOLLOWER	2	U251
21	3/8-24 X 3/8 DOG POINT	2	H515
22	LABEL: ROTARY VALVE - BLUE	1	PA228
23	O-RING-130	2	VO-130
24	VALVE BODY	1	PA221
25	CAP	1	PA224
26	O-RING-135	1	VO-135
27	SEAT	1	PA223
28	VALVE	1	PA222
29	INLET ADAPTER	1	PA225
30	3/16" SS BALL (34) PER RACE	68	V2120
31	PORT PLUG	2	B770
32	O-RING-134	2	VO-134
33	GASKET GRABBER	1	G606
34	COUPLING 1.5"	2	G690*
35	GASKET - 1.5" HOSE COUPLING	2	V3130
36	STORAGE BAG	1	PA200
37	MATE	1	PA264
38	NOZZLE BASE	1	PA261
39	HEX PORT PLUG	1	PA265
40	NOGGIN	3	PA262
41	SPINNER	3	PA263
<b>* - CONSULT FACTORY FOR SPECIAL THREADS</b>			

## 9.0 INSPECTION AND MAINTENANCE

The Task Force Tips Transformer Nozzle System is designed and manufactured to be damage resistant and require minimal maintenance. However, as the primary firefighting tool upon which your life depends, it should be treated accordingly.

Nozzle must be inspected before each use for proper operation and function according to this checklist:

- None of the nozzle jets are clogged
- There is no obvious damage such as missing, broken or loose parts, etc
- The threaded joints between component are hand tight and leak free
- The coupling is tight and leak free
- Valve opens and closes freely

### **⚠ WARNING**

Before each use nozzle must be inspected for proper operation and function according to inspection criteria above. Any nozzle that fails inspection is dangerous to use and must be repaired before using. Operating a nozzle that fails any part of the inspection is a misuse of this equipment.

### **⚠ WARNING**

Performance tests shall be conducted on the special purpose nozzle after a repair, or anytime a problem is reported to verify operation in accordance with Task Force Tips test procedures. Consult factory for the procedure that corresponds to the model of the nozzle. Any equipment which fails the related test criteria should be removed from service immediately. Equipment can be returned to the factory for service and testing.

### **⚠ CAUTION**

Any alterations to the equipment constitutes a misuse of this product and could diminish safety.

### **⚠ CAUTION**

Maximum operating pressure 300 psi (20 bar). Do not exceed 300 psi (20 bar) on either side of the valve.

### **⚠ CAUTION**

Transformer Nozzle System must be properly connected. Mismatched or damaged connectors may cause leaking or uncoupling under pressure and may cause injury.

### **⚠ CAUTION**

Dissimilar metals coupled together can cause galvanic corrosion that can result in the inability to unscrew the threads or complete loss of thread engagement over time. Per NFPA 1962 (2013 Edition), if dissimilar metals are left coupled together an anti-corrosive lubricant should be applied to the threads. Also the couplings should be disconnected and inspected at least quarterly.